

2017

The self-distracting mind in the digital age: Investigating the influence of a brief mindfulness intervention on mind wandering

Caglar Yildirim
Iowa State University

Follow this and additional works at: <http://lib.dr.iastate.edu/etd>

 Part of the [Cognitive Psychology Commons](#), [Computer Sciences Commons](#), and the [Other Psychology Commons](#)

Recommended Citation

Yildirim, Caglar, "The self-distracting mind in the digital age: Investigating the influence of a brief mindfulness intervention on mind wandering" (2017). *Graduate Theses and Dissertations*. 15470.
<http://lib.dr.iastate.edu/etd/15470>

This Dissertation is brought to you for free and open access by the Iowa State University Capstones, Theses and Dissertations at Iowa State University Digital Repository. It has been accepted for inclusion in Graduate Theses and Dissertations by an authorized administrator of Iowa State University Digital Repository. For more information, please contact digirep@iastate.edu.

The self-distracting mind in the digital age: Investigating the influence of a brief mindfulness intervention on mind wandering

by

Caglar Yildirim

A dissertation submitted to the graduate faculty
in partial fulfillment of the requirements for the degree of

DOCTOR OF PHILOSOPHY

Major: Human Computer Interaction

Program of Study Committee:
Veronica J. Dark, Major Professor
Douglas A. Gentile
Jonathan Kelly
Christian A. Meissner
Mack C. Shelley

The student author and the program of study committee are solely responsible for the content of this dissertation. The Graduate College will ensure this dissertation is globally accessible and will not permit alterations after a degree is conferred.

Iowa State University

Ames, Iowa

2017

Copyright © Caglar Yildirim, 2017. All rights reserved.

DEDICATION

To my mother, father, and brother...

TABLE OF CONTENTS

LIST OF FIGURES.....	v
LIST OF TABLES	vi
ACKNOWLEDGMENTS	vii
ABSTRACT	viii
CHAPTER 1. INTRODUCTION.....	1
Mind Wandering.....	4
Attention and mind wandering.....	4
External and internal attention.....	6
How is mind wandering studied?.....	9
Theoretical explanations of mind wandering.....	14
Reconciling the four hypotheses: The process-occurrence framework.....	27
Mind wandering in educational settings	31
Mindfulness	35
Attention and mindfulness	37
Effects of mindfulness training on attention.....	39
Mindfulness and mind wandering	48
CHAPTER 2. EXPERIMENT 1	51
Method.....	55
Results	63
Discussion	84
CHAPTER 3. EXPERIMENT 2	92
Method.....	93
Results	96
Discussion	102
CHAPTER 4. CORRELATIONAL EXAMINATION	105
Method.....	108
Results	109
Discussion	112
CHAPTER 5. GENERAL DISCUSSION	114
REFERENCES	126

APPENDIX A. MIND WANDERING QUESTIONNAIRE	138
APPENDIX B. MEDIA MULTITASKING INDEX.....	139
APPENDIX C. MINDFUL ATTENTION AWARENESS SCALE.....	140
APPENDIX D. DISSOCIATIVE EXPERIENCES SCALE.....	141
APPENDIX E. TORONTO MINDFULNESS SCALE.....	144
APPENDIX F. RETROSPECTIVE MEASURE OF MIND WANDERING.....	146
APPENDIX G. POST-VIDEO QUESTIONNAIRE.....	147
APPENDIX H. THE COMPREHENSION TEST USED IN EXPERIMENT 1	148
APPENDIX I. THOUGHT SAMPLING INSTRUCTIONS	151
APPENDIX J. CORRELATIONS AMONG STUDY VARIABLES IN EXPERIMENT 1	152
APPENDIX K. ADDITIONAL ANALYSIS FOR WORKING MEMORY CAPACITY	153
APPENDIX L. DESCRIPTIVE STATISTICS FOR SART PERFORMANCE MARKERS.....	155
APPENDIX M. INSTITUTIONAL REVIEW BOARD APPROVAL.....	156

LIST OF FIGURES

Figure 1. A schematic overview of external and internal attention.....	7
Figure 2. The thought sampling paradigm used in Experiment 1.....	62
Figure 3. Bar graphs for each dependent measure in Experiment 1	66
Figure 4. Regression coefficients for the relationship between working memory capacity and lecture comprehension as mediated by mind wandering.....	73
Figure 5. Structural equation model testing the effects of interest and background knowledge on lecture comprehension as mediated by mind wandering.....	82
Figure 6. Example SART trials.....	95
Figure 7. Bar graphs for each dependent variable in Experiment 2.....	98
Figure 8. SART errors as a function of task block.....	101
Figure 9. RT CV as a function of task block.....	102
Figure 10. The mediating role of trait mindfulness in the relationship between media multitasking and mind wandering.....	110
Figure K1. Additional analysis for the relationship between working memory capacity and lecture comprehension as mediated by mind wandering.....	154
Figure L1. Bar graphs for the mean values of SART measures in Experiment 2.....	155

LIST OF TABLES

Table 1. Descriptive statistics for dependent variables	65
Table 2. Correlations among the dependent variables	65
Table 3. ANOVA results for dependent variables	67
Table 4. Descriptive statistics for individual differences measures across conditions...	71
Table 5. Correlations among individual differences measures across all participants...	72
Table 6. Exploratory regression analysis predicting mind wandering.....	74
Table 7. Moderation effects of individual differences measures on the relationship between mind wandering (TUT) and lecture comprehension (COMP)	77
Table 8. Loadings of manifest variables on latent variables	79
Table 9. Correlations among latent variables	79
Table 10. Loadings of manifest variables on latent variables without the Motivation factor.....	80
Table 11. Correlations among latent variables without the Motivation factor.....	80
Table 12. Path coefficients for the hypothesized mediation model	82
Table 13. Correlations among individual differences measures across all participants from both experiments	110
Table J1. Correlations among all study variables in Experiment 1	152

ACKNOWLEDGMENTS

First and foremost, I would like to wholeheartedly thank my advisor Veronica Dark for her unwavering patience, support, and guidance. I feel honored to be one of her last two PhD students before her (well-deserved but overdue) retirement. She has taught me, both explicitly and implicitly, how to be a critical researcher and how to be a great professor. I sincerely appreciate all her contributions of time and ideas to my academic development. Her dedication to helping everyone around her achieve their potential and become what they are capable of becoming has been motivational for me. The joy and enthusiasm she has for teaching was especially inspiring. I will always be mindful of the excellent example she has provided as a caring advisor, critical researcher, and dedicated professor.

I also wish to express my appreciation to my committee members of Douglas Gentile, Jonathan Kelly, Christian Meissner, and Mack Shelley for their guidance, support, and invaluable suggestions, as well as for their patience with my geeky metaphors inspired by Harry Potter throughout my dissertation and presentations.

Furthermore, I would like to thank my friends in Ames who were always there for me whenever I needed. I would also like to thank all of my friends in Turkey who believed in me and trusted me that I could achieve my goals.

Finally, I would like to thank my mother, father, and brother for their unconditional encouragement, trust, and love.

ABSTRACT

Mind wandering is a pervasive aspect of mental life. Wandering minds often lead to performance decrements during demanding tasks that require concentration, highlighting the need for devising strategies to ward off mind wandering and to mitigate its deleterious effects on task performance. Accordingly, this dissertation investigated whether a brief mindfulness intervention could reduce mind wandering. Experiment 1 examined the influence of the brief mindfulness intervention on mind wandering during an ecologically valid sustained attention task, i.e., learning from a lecture video, and on the disruptive effects of mind wandering on lecture comprehension. Experiment 1 provided no supporting evidence for the beneficial influence of the brief intervention on the occurrence of mind wandering during the lecture video, nor on the disruptive effects of mind wandering on lecture comprehension. Experiment 2 examined whether the brief mindfulness intervention could reduce behavioral indices of mind wandering during a widely-used sustained attention to response task (the SART). Experiment 2 produced no evidence for the beneficial influence of the brief intervention on mind wandering during the SART either. Taken together, the current experiments indicate that the brief mindfulness intervention employed in this dissertation exerted no beneficial effects on attentional control and mind wandering during demanding tasks, underscoring the importance of examining more robust mindfulness interventions in future investigations.

The dissertation also examined the mediating role of self-reported trait mindfulness in the relationship between self-reported media multitasking frequency and

mind wandering tendency. The mediation analysis revealed that trait mindfulness partially mediated the relationship between media multitasking frequency and mind wandering tendency. This partial mediation model suggests that habitual media multitasking is associated with an increased proclivity for mind wandering and that increased frequency of media multitasking is associated with lower levels of mindfulness, which is in turn associated with greater propensity for mind wandering. Therefore, it is plausible that habitual media multitaskers may find it onerous to prevent their minds from wandering because they compromise top-down attentional control while frequently and consistently switching attention among multiple forms of media, diminishing their ability to stay focused on a single task.

CHAPTER 1. INTRODUCTION

Harry had a lot of trouble keeping his mind on his lessons that day. It kept wandering up to the dormitory where his new broomstick was lying under his bed, or straying off to the Quidditch field where he'd be learning to play that night. He bolted his dinner that evening without noticing what he was eating, and then rushed upstairs with Ron to unwrap the Nimbus Two Thousand at last (Rowling, 1997, p. 166).

So begins the story of Harry's first experience with Quidditch in J. K. Rowling's book *Harry Potter and the Sorcerer's Stone*. If you are Harry Potter, who, at the age of 11, found out that he was a wizard and that he was accepted to the Hogwarts School of Witchcraft and Wizardry, and if you have recently received a broomstick, with which witches and wizards fly, to join the Quidditch (soccer game in the magic world, in which players fly with their broomsticks and pass around a ball among each other to score against the opponent team) team as the youngest Quidditch player Hogwarts has seen in a century, it is no wonder why your mind kept wandering up to your dormitory and your thoughts kept straying away from your classes off to the Quidditch field on this very first day that you are going to learn to play Quidditch.

That being said, you do not have to be a wizard or witch for your mind to wander. Nor do you need to have a broomstick - the latest model of the time indeed - for your mind to stray off to thoughts that have nothing to do with a primary task in which you might be engaged. Our *Muggle* (nonmagic) lives are already replete with opportunities conducive to mind wandering. For instance, anyone who has tried to work in the office on a bright sunny day can attest to the somehow inevitable experience of mind wandering. In fact, experience

sampling studies in daily life settings demonstrate that people mind wander between 25% and 50% of the time (Killingsworth & Gilbert, 2010; McVay, Kane, & Kwapil, 2009).

Mind wandering represents a drift of attention from an external, ongoing task to an internal train of thought that is not relevant to the immediate task. In other words, individuals are not always engaged in task-related thoughts as they are completing a task. During mind wandering, individuals are said to engage in task-unrelated thoughts (TUTs) (Giambra 1989), stimulus-independent thoughts (Antrobus, Singer, & Greenberg, 1966), or self-generated thoughts unrelated to an ongoing task (Smallwood, 2013). These terms are often used interchangeably, as they describe the experience of engaging in off-task thinking while on task. For purposes of this dissertation, TUTs will be used to refer to the experience of mind wandering, and task-related thoughts will be used to refer to the states of on-task thinking.

Within the past decade, research on mind wandering has flourished for several reasons, including the increased scholarly interest in cognitive processes independent of exogenous input (e.g., internal attention), the advances in neuroimaging techniques, and the development of experimental paradigms for studying mind wandering under various conditions (Smallwood & Schooler, 2015). One widely used paradigm to measure mind wandering is thought sampling, in which participants are sporadically probed during the task and asked to indicate whether they are on-task or off-task (Schooler et al., 2011). In a slightly different version of thought sampling, the self-caught method, participants are asked to provide spontaneous reports of off-task thinking by pressing a specific key anytime they notice themselves mind wandering (Smallwood & Schooler, 2006).

Although this mental experience of mind wandering has been shown to be beneficial under certain circumstances, e.g., autobiographical planning, avoiding boredom, etc. (Smallwood & Schooler, 2015), it has been associated with performance decrements on diverse tasks, including sustained attention tasks (McVay & Kane, 2009), reading comprehension (Smallwood et al., 2008), and listening to lectures (Risko, Anderson, Sarwal, Engelhardt, & Kingstone, 2011). The question, hence, becomes what strategies are effective in reducing the occurrence of mind wandering during tasks requiring sustained attention and in reducing performance costs associated with mind wandering. One plausible strategy that is being increasingly investigated in the mind wandering literature is mindfulness meditation training (MMT). Mindfulness can be thought of as the art of paying attention to the present moment and refining moment-to-moment awareness, capitalizing on one's capacity for self-awareness and self-knowing (Kabat-Zinn, 2005). MMT has been proposed as an antidote for wandering minds (Mooneyham & Schooler, 2013; Mrazek, Smallwood, & Schooler, 2012).

The challenge of regulating mind wandering during sustained attention tasks and reducing its disruptive effects on task performance is especially applicable to educational settings, as mind wandering is likely to occur during lectures and/or while studying (Unsworth, McMillan, Brewer, & Spillers, 2012). Therefore, this dissertation primarily aims to address the following question:

Does a brief mindfulness mediation influence the occurrence of mind wandering during an ecologically valid sustained attention task, learning from a lecture video?

Mind Wandering

Attention and mind wandering

Attention is a fundamental cognitive mechanism that allows individuals to select, filter, and process the abundance of information coming from the external environment through the senses, as well as internally-generated information and mental representations (Eysenck & Keane, 2015), as illustrated in the following quote by William James (1890):

Everyone knows what attention is. It is the taking possession by the mind, in clear and vivid form, of one out of what seem several simultaneously possible objects or trains of thought. Focalization, concentration, of consciousness are of its essence. It implies withdrawal from some things in order to deal effectively with others... (pp. 403-4).

While the definition of attention is not so clear to many contemporary researchers, this famous quote touches upon the essential characteristics of attention with its description of attention as selectivity of processing. Attention is involved in focusing limited processing capacity on selected information, modulating the processing of selected information and sustaining vigilance (Chun, Golomb, & Turk-Browne, 2011). Basically, attention plays a key role in everyday life and serves innumerable practical and vital functions, varying from enabling the reading of a paper to affording the ability to avoid bumping into people in public.

As William James (1890) put forward, attention can be directed to “objects” or “trains of thought”. An individual can focus attention on external stimuli or internal thoughts or images, sustain it, orient it to something else, and redirect it back to the original focal point

once strayed away from it. The ability to sustain attention for longer periods of time is remarkable and is necessary in diverse contexts. For instance, individuals need to sustain attention on what a friend is saying during a conversation or on the road while driving. Similarly, as a reader, you need to sustain attention on this paper to identify, encode, and parse words and transform them into meaningful sentences while building a situation model of the text to facilitate your comprehension. Nonetheless, for many people, attention is not sustained on task-relevant stimuli all the time and most people's attention tends to falter and wane, leading to temporary attentional lapses during an ongoing task or total attentional disengagement from the task (Smallwood et al., 2008).

These breakdowns in attention reflect interference from information irrelevant to a current task in the pursuit of task-relevant goals and/or activities (Mishra, Anguera, Ziegler, & Gazzaley, 2013). Just as this interference can originate from external sources of information, it can also be generated from internal information sources (Mishra et al., 2013). External interference, including distractions and interruptions, is caused by external stimuli coming through the senses. Internal interference, on the other hand, is generated from internal trains of thoughts. Regardless of whether or not the interference is from external or internal causes, attentional lapses can have negative consequences in a variety of situations that require individuals to sustain attention while accomplishing their goals and tasks (Schacter & Szpunar, 2015).

While the effects of external interference on attention have been widely investigated, scholarly interest in attentional lapses due to internal interference has surged in recent years. One type of internal interference that has recently received attention from scientific

community is mind wandering. Mind wandering is a type of internal interference in which attention drifts away from a current, ongoing task and relevant external stimuli to self-generated, internal thoughts unrelated to the task at hand (i.e., TUTs). This attentional shift is characterized by a state of perceptual decoupling, whereby attention is disengaged from perception of external stimuli and instead is focused on an internal train of thoughts (Schooler et al., 2011; Smallwood & Schooler, 2015). Thus, when the mind wanders, attention is derailed from an extrinsic task to an intrinsic train of TUTs.

External and internal attention

Because mind wandering is characterized by a shift of attention away from an ongoing task and relevant external stimuli to self-generated, internal information unrelated to the task at hand, distinguishing between external and internal attention can provide greater insight into mind wandering. In their taxonomy of external and internal attention, Chun et al. (2011) offered a distinction between external and internal attention with respect to where attention is directed, that is, the targets of attention. While there are different views on attention, they explain the same phenomena using different terminology applied to identical concepts. Therefore, the taxonomy of external and internal attention will be used as a guide to describe the attentional processes involved in mind wandering. Key elements from two other accounts of attention, working memory and executive control, will be incorporated into the discussion of mind wandering from the perspective of this taxonomy.

Figure 1 presents a schematic overview of the taxonomy of external and internal attention. On opposite ends of a continuous axis are external and internal attention. Each box represents a target of attention and these boxes, especially the ones at the same level, are

interactive to a large extent. The interaction among different levels is characterized by goal-directed, top-down attention and stimulus-driven, bottom-up attention, as represented by the arrows.

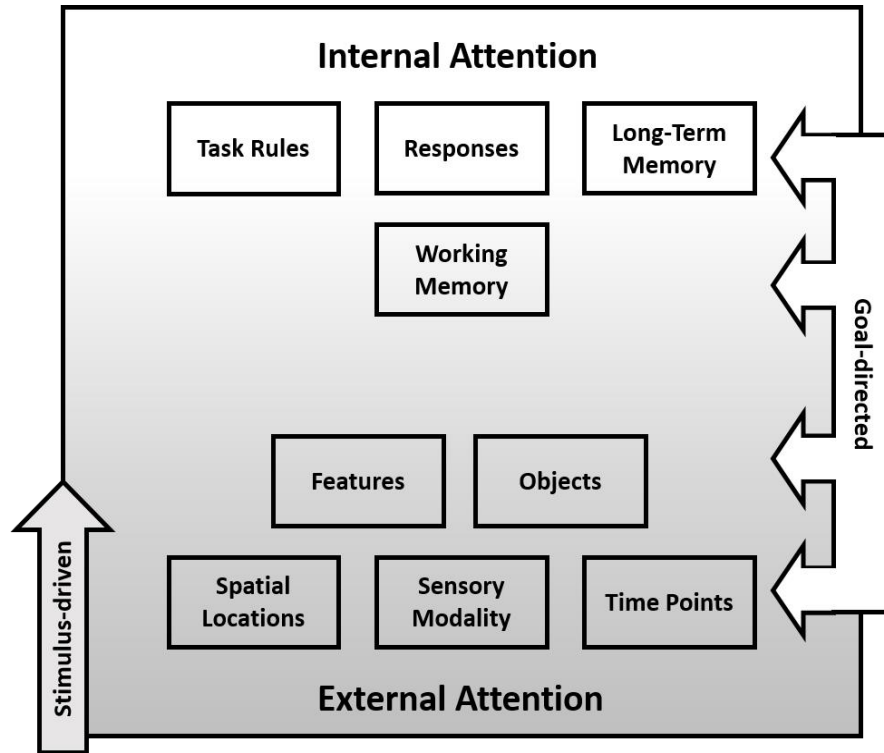

Figure 1. A schematic overview of external and internal attention. On opposite ends of a continuous axis are external and internal attention. Each box represents a target of attention and these boxes, especially the ones at the same level, are interactive to a large extent. The arrows on the right represent goal-directed attention and the arrow on the bottom left represents stimulus-driven attention.

In the taxonomy of Chun et al. (2011), external attention is involved in selecting and modulating sensory input and internal attention is involved in selecting, modulating, and maintaining self-generated internal information such as the contents of working memory. Thus, external attention is mainly concerned with perceptual attention to external stimuli, and internal attention is concerned with central or reflective attention to inner cognitive processes. While the targets of external attention are exogenous inputs coming in through

senses, the targets of internal attention are mental representations being encoded and maintained in working memory and/or retrieved from long term memory as well as internal trains of thoughts.

As Eysenck and Keane (2015) pointed out, the role of working memory is crucial to understanding the interplay between external and internal attention. In their taxonomy, Chun et al. (2011) considered working memory as a distinct internal attention process on the grounds that what is being processed and maintained in working memory involves internal representations of external input that is not available any more. Within this taxonomy, working memory is placed at the interface between external and internal attention and is involved in the modulation of processing of relevant information and suppression of irrelevant information, drawing close parallels to Baddeley's (2012) working memory model. The central executive component of working memory is especially of relevance and of great importance because it is functionally involved in various executive processes, including focusing attention, dividing attention between two targets, switching attention between tasks and interfacing with long term memory (Baddeley, 2012). Considering that working memory has a limited capacity (Baddeley, 2012; Chun et al., 2011), the central executive component plays a key role in selection and prioritization of what will be processed in working memory, which can be further explained by another account of executive processes – executive control theory (Engle & Kane, 2004).

According to the executive control theory (Engle & Kane, 2004; Kane & Engle, 2002), executive control refers to the control of attentional or cognitive resources for the purposes of maintaining goals and achieving tasks in the presence of interference or distraction.

Executive control is generally regarded as a domain-general ability to direct attention to a task, to maintain it on the ongoing task, and to redirect attention to the ongoing task after becoming distracted. Thus, executive control involves the ability to focus and sustain attention on the task at hand and the ability to suppress interference or distractions. In other words, executive control reflects the ability to maintain the attentional control on task-relevant information while at the same time inhibiting task-irrelevant information.

Based on the executive control theory, mind wandering reflects a temporary lapse in executive control such that maintenance of task goals is disrupted by internal interference or TUTs. From the external and internal attention perspective (Chun et al., 2011) then, mind wandering reflects an attentional state in which internal trains of thoughts gain dominance over exogenous stimuli in working memory, and thus, mental representations of internally-generated information become so salient that external attention or attention to perceptual information is diminished. Put another way when the mind wanders, the contents of internal attention are prioritized, encoded and maintained in working memory, leaving little deep processing capacity for perceptual information from external attention.

How is mind wandering studied?

Measures of mind wandering. Studies on mind wandering utilize thought sampling to capture individuals' subjective mental experience while they are completing a task in laboratory settings (Smallwood & Schooler, 2006, 2015). There are two categories of thought sampling: the probe-caught method and the self-caught method. In the probe-caught method, participants are intermittently probed and asked to report on the contents of their thought (Antrobus et al., 1966; Giambra, 1995; Schooler, Reichle, & Halpern, 2005;

Smallwood & Schooler, 2006, 2015). In the self-caught method, participants are asked to provide spontaneous reports, usually by pressing a specific key on the keyboard, anytime they notice they have been mind wandering as they complete a task (Cunningham, Scerbo, & Freeman, 2000; Giambra, 1993; Smallwood & Schooler, 2006, 2015). Thought sampling is also used in ecologically valid settings to capture the contents of individuals' thoughts in daily life and this is known as experience sampling (Smallwood & Schooler, 2015).

When used together, the probe-caught and self-caught methods can complement each other and can provide greater insight into individuals' subjective mental experience than could be obtained by using either method alone (Smallwood & Schooler, 2006, 2015). The self-caught method provides an estimate of mind wandering episodes of which individuals are aware, whereas the probe-caught method can provide an estimate of mind wandering episodes of which individuals are not aware (Schooler et al., 2005). If an individual reports that he or she has been mind wandering at the time of the probe, this indicates that the individual was not aware that he or she had been mind wandering before being probed, because otherwise the individual would have reported that they had been mind wandering by pressing the assigned key before the probe appeared.

While the validity of these self-reported measures of mind wandering may be questioned, they have been extensively used in previous studies and have been triangulated with objective measures. Previous studies have found variation in response time in relation to the reports of mind wandering (Carriere, Cheyne, & Smilek, 2008; Cheyne, Carriere, Solman, & Smilek, 2011; McVay & Kane 2009) and have shown that variability in mind wandering is linked to changes in the pattern of eye movements (Foulsham, Farley, &

Kingstone, 2013; Reichle, Reineberg, & Schooler, 2010), in pupil dilation (Franklin, Broadway, Mrazek, Smallwood, & Schooler, 2013; Smallwood et al., 2011), and in the frequency of eye blinks (Smilek, Carriere, & Cheyne, 2010). Mind wandering reports have also been associated with changes in electroencephalography (EEG) signals (Baird, Smallwood, Lutz, & Schooler, 2014; Barron Riby, Greer, & Smallwood, 2011; Kam et al., 2011) and in the blood-oxygen-level dependent (BOLD) signals during functional magnetic resonance imaging (fMRI) scans (Allen et al., 2013, Christoff, Gordon, Smallwood, Smith, & Schooler, 2009, Stawarczyk, Majerus, Maj, Van der Linden, & D'Argembeau, 2011). Considering the link between self-reported measures of mind wandering and behavioral and neurocognitive markers of mind wandering, the probe-caught and self-caught methods can be used to study mind wandering in laboratory settings.

Tasks used to study mind wandering. Investigations of mind wandering have used various tasks to examine the occurrence of mind wandering while participants are completing those tasks and the effects of mind wandering on task performance. One of the most widely used tasks to study mind wandering is the Sustained Attention to Response Task (SART; Robertson et al., 1997). The SART is a go/no-go sustained attention task in which participants are shown an array of visual stimuli of a single category (e.g., letters or numbers) and are asked to respond to nontargets and to withhold response to targets (e.g., letter X or number 3). In the SART, targets occur rarely. For instance, during an SART with 240 trials, there may be only 16 targets. Go/no-go stimuli are usually presented for a short duration (e.g., 300ms) followed by a mask (e.g., an encircled circle). SART errors, or the failures to withhold response to the no-go targets, are considered as failures of sustained attention,

instead of failures to inhibit response (Manly et al., 1999; Robertson et al., 1997). SART errors are calculated based on the accuracy rates in withholding responses to targets. Another SART measure that is often used is reaction time variability, also known as reaction time coefficient of variability (RT variability). RT refers to the time elapsed between the presentation of a stimulus and the onset of a response. RT variability represents the variation in response times to nontargets and is calculated as the standard deviation for nontarget reaction times on the SART divided by the mean of RT. SART errors are interpreted as reflecting a drift of attention from the ongoing task, whereas RT variability is regarded as reflecting subtle attentional lapses (e.g., McVay & Kane, 2009, 2012a). Thus, increased SART errors reflect an increase in failure to maintain sustained attention and increased RT variability reflects increased attentional fluctuations.

The SART has been extensively used in the mind wandering literature to study the occurrence of mind wandering in situations that require individuals to maintain sustained attention as well as its effects on such a resource-demanding task (Cheyne, Solman, Galloway, & Hawkins, 2009; McVay & Kane, 2009; Mrazek et al., 2012; Smallwood et al., 2004, 2006). Investigations of mind wandering during the SART involve participants completing the task and being probed throughout the task or completing a retrospective posttest questionnaire to indicate how much they have mind wandered while working on the task. For instance, McVay and Kane (2009) had participants complete a modified version of the SART task with word stimuli, usually known as the semantic SART (Smallwood, Riby, Heim, & Davies, 2006), and probed the participants following the targets. The semantic SART presented 1800 words in 8 blocks, each of which consisted of 225 trials with 45 words

repeated randomly. Of these 45 words, 40 were nontargets, animal names, and 5 were targets, names of foods. Each word was shown for 300ms and then was followed by a 900ms mask, which was 12 capitalized Xs (i.e., XXXXXXXXXXXX). McVay and Kane (2009) found that participants made more errors on withholding responses to the targets when they reported mind wandering than when they reported on-task thinking. Also, results indicated that increased mind wandering was associated with increased performance decrements on the SART (i.e., increased failures of withholding response to targets) over time. RT variability in responses to nontargets was positively correlated with the number of mind wandering episodes. Overall performance on the SART, including both correctly responding to nontargets and withholding responses to targets, was inversely associated with the number of mind wandering episodes. Performance results on the SART have usually been interpreted in this manner in studies using this task (Cheyne et al., 2009; McVay & Kane, 2009; Mrazek et al., 2012; Smallwood et al., 2004, 2006).

Another task that has been widely used to study mind wandering is reading. Investigations of mind wandering during reading utilize a similar design in which participants read some material and report TUTs when probed and/or when they catch themselves mind wandering. Previous studies have shown that mind wandering is a common experience while reading and that mind wandering during reading leads to poor comprehension of the reading material (Mrazek, Franklin, Phillips, Baird, & Schooler, 2013; Reichle et al., 2010; Schooler et al., 2005; Smallwood et al., 2008; Smilek et al., 2010).

While the majority of studies have examined mind wandering while participants are engaged in the SART or reading tasks, a few studies have studied mind wandering while

participants are learning from lecture videos (Farley, Risko, & Kingstone, 2013; Risko et al., 2012; Risko, Buchanan, Medimorec, & Kingstone, 2013; Szpunar, Moulton, & Schacter, 2013). Similar to the SART and reading tasks, investigations of mind wandering during lecture videos use thought sampling when participants are watching a lecture video and examine the effects of mind wandering on the comprehension of lecture video material. These studies have also provided evidence for the disruptive effects of mind wandering during lecture videos on the comprehension of lecture material.

Theoretical explanations of mind wandering

Over the past decade, the literature on mind wandering has surged and revolved around four main hypotheses regarding the cognitive basis of mind wandering, namely the current concerns hypothesis, the decoupling hypothesis, the executive failure hypothesis, and the meta-awareness hypothesis.

The current concerns hypothesis. As one of the early accounts of mind wandering, the current concerns hypothesis is based on Klinger's (1971, 1999) work on thought flow and how task-relevant goals and current concerns alter the contents of a train of thought. In this framework, current concerns refer to "latent time-binding states that extend from the initiation of commitment to a goal pursuit to its termination" (Klinger, 1999, p. 29). An individual's personal goals, daily life issues, and unresolved problems are examples of current concerns.

The basic tenet of the current concerns hypothesis is that the focus of attention is on salient experiences, whether they be internal or external (Klinger, 1999, 2013). Current concerns become salient when individuals are preoccupied with thoughts related to

themselves during a period in which external events provide relatively less prominent stimuli. The salience of current concerns and of perceptual information is determined by the priorities and the emotional value for an individual. At a given moment, an individual may have various concerns, varying from one's to-do list for the week to an upcoming vacation. During a weekly office meeting, for example, an upcoming vacation may be more prominent for an individual if the individual finds the meeting agenda boring or mundane. The individual's current concerns (goals, wishes, or desires related to the vacation), which are emotionally more valuable to the individual, could become more salient than the meeting discussion, providing the impetus for engaging in self-generated thoughts unrelated to the external task – attentively listening to the meeting. Thus, self-generated TUTs become the target of attention when incoming perceptual information is not as salient as an individual's current concerns. According to the current concerns hypothesis, then, the mind wanders more frequently when the incentive of engaging in self-generated TUTs is higher than paying attention to external input.

According to the current concerns hypothesis, mind wandering refers to a mental state in which the content of thought strays away from a current task and focuses instead on self-generated thoughts unrelated to the task (Klinger, 2013). What leads to this shift in mental content is the availability of internal and/or external cues that may prime some concerns about a goal (e.g., planning an upcoming vacation, submitting an assignment on time, or checking email) due to the heightened sensitivity of the individual to such cues. Responses to these cues may be in the form of overt actions or subjective mental activity. On one hand, when the individual is able to work toward the attainment of the primed goal, the

individual's response to these cues will involve taking actions to pursue that goal. For example, when reading a paper, an individual may receive a smartphone notification, which may provide an external cue for the individual to think about what is new on Facebook. In response to this cue, the individual can check his or her smartphone to receive the recent updates from Facebook, and thus, attain the goal of checking Facebook primed by the incoming notification (i.e., an external cue). On the other hand, under circumstances that do not allow the pursuit of goals, the responses are in the form of mentation. That is to say, individuals can only mentally respond to such cues due to the environmental constraints. Using the above example, if the individual is taking a test and his or her smartphone buzzes to indicate the arrival of a notification, this may prime the thought of checking the smartphone for what is new. Being unable to pull out the smartphone in the middle of the test, the individual's response to this potent cue may be to engage in thoughts related to checking the smartphone while working on the test. Hence, the individual engages in mind wandering rather than focusing on the test.

Just as the thought of checking one's smartphone could be primed by external cues, it could also originate from internal cues. The individual could feel a desire to check his or her smartphone during the test because of his or her interest in finding out what is new on Facebook. Having noticed the internal cue (i.e., the urge to check Facebook), the individual could decide either to worry about it after the test and continue working on the test or to engage in thoughts related to what may be happening on Facebook, leading to mind wandering.

When the individual's goal is to sustain attention on the ongoing task, task-related thoughts will be prioritized, leading to declines in mind wandering. In this case, TUTs related to the current concerns of an individual are less saliently represented than are task-related thoughts. By contrast, when the individual's current concerns become more salient, representations of those concerns will be prioritized in the individual's thought stream, resulting in increases in mind wandering. The current concerns hypothesis, accordingly, argues that the shift in mental content from thoughts related to an ongoing task to thoughts unrelated to the task at hand, that is, mind wandering, is more likely when task demands are low and require fewer cognitive resources. Also, the current concerns hypothesis (Klinger 1999, 2013) suggests that current concerns are more likely to be activated when performance costs associated with mind wandering are not high.

Support for the current concerns hypothesis comes from studies in which the salience of personal memories or goals is manipulated before participants perform an experimental task. In an early study of this kind, Antrobus et al. (1966, Experiment 3) investigated whether experimentally inducing a current concern would lead to an increase in TUTs during a signal-detection task. Participants in the experimental group were exposed to a radio broadcast of music, which was interrupted by a bogus bulletin announcing that the Chinese Communists had attacked a US air base and entered the war in Vietnam. After broadcasting Communist China's declaration of war on the United States, the bulletin went on to announce that eligible men would be called in for health screening by local draft boards. In doing so, the researchers primed the participants in the experimental group to think about the implications of this recent news for themselves as well as their friends and families, leading to a more salient

current concern for them. Participants in the control group listened to the radio broadcast of music for 15 minutes without an interruption. Results indicated that the experimental group reported having more TUTs than the control group. More recent studies have provided further support for the current concerns hypothesis. It has been shown that priming of personal goals during a writing task prior to task performance results in increased number of future-oriented TUTs (Stawarczyk et al., 2011).

The executive failure hypothesis. Based on the executive-attention theory of working memory capacity (Kane et al., 2007), McVay and Kane (2009) argued that mind wandering reflects an executive-control failure in the maintenance of task-related thoughts during a primary task. According to the executive failure hypothesis (McVay & Kane, 2009, 2010), the generation of TUTs is automatic and continuous with regards to internal and external cues. In this account of mind wandering, TUTs are generated and maintained in a resource-free manner, which is why they are always available in the thought stream. It is executive-control resources that suppress TUTs, preventing them from becoming the focus of attention, while at the same time ensuring the continuity of task-related thoughts during a resource-demanding primary task.

Because mind wandering reflects a shift of attention from a resource-demanding task to self-generated TUTs, McVay and Kane (2009, 2010) argued that it originates from temporary failures in executive control, one function of which is to ensure sustained attention on the primary task in the face of external and internal interference. Executive control prevents TUTs from intruding into consciousness in a top-down manner and the exertion of this top-down control on mind wandering can be both proactive and reactive

(McVay & Kane, 2010). Executive control is proactively initiated to maintain sustained attention on the primary task and to allocate attentional resources to the processing of the representations of task-relevant information in lieu of TUTs. When executive control fails to proactively ensure the continuity of task-relevant goals, TUTs intrude into consciousness, leading to performance decrements on the primary task because attention is diverted from the primary task to TUTs. Executive control is reactively initiated to draw attention back to the primary task when TUTs have already become the focus of attention due to temporary lapses in proactive control. Therefore, the engagement of reactive executive control is necessary to subdue TUTs. Accordingly, the executive failure hypothesis argues that executive-control prevents the mind from wandering by keeping the focus of attention on task-relevant stimuli and blocking interference from TUTs and that individual differences in executive control capabilities play a key role in the propensity for mind wandering.

As a measure of domain-general ability, working memory capacity (WMC) is used to assess an individual's executive control capabilities and individual differences in working memory capacity have been of great interest to researchers in this field (Engle & Kane, 2004). Consequently, the executive-control failure account of mind wandering has focused on the relationship between WMC and mind wandering. According to the executive-attention theory of WMC (Kane et al., 2007), individual differences in WMC reflect variations in executive control capabilities and more specifically in the maintenance of task-relevant goals in the face of interference. Consequently, individuals with higher WMC demonstrate superior executive control capabilities than individuals with lower WMC, because they are better at goal maintenance and conflict resolution (i.e., dealing with interference).

Based on the executive-attention theory of WMC (Kane et al., 2007), McVay and Kane (2010) suggested that individual differences in WMC, and thus in executive control capabilities, predict variations in the propensity to mind wander. Hence, according to the executive failure hypothesis, individuals with low WMC are more likely to mind wander during resource-demanding tasks. Moreover, considering that mind wandering occurs as a result of temporary failures in executive control and that this executive control failure leads to performance decrements, McVay & Kane (2009) contended that variations in mind wandering partially influence performance differences due to individual variations in WMC, suggesting that the relation between WMC and task performance is partially mediated by mind wandering.

Both daily life and laboratory studies have provided support for the predictions of the executive failure hypothesis. Kane et al. (2007) conducted an experience sampling study in which they investigated the relationship between executive control and mind wandering in daily life. Prior to the onset of the experience sampling procedure in daily life settings, they had college students come in to the lab to complete WMC tasks. Later, the authors asked these college students to report on their thoughts by intermittently probing them multiple times a day throughout a period of seven days, using personal digital assistants provided to them for this purpose. Results indicated that college students with higher WMC had fewer TUTs and more task-related thoughts, compared to those with lower WMC during daily activities that were characterized by the students as requiring concentration, effort, or challenge.

In another study, McVay and Kane (2012b) investigated the relationship between WMC and mind wandering during reading. For this purpose, they had college students complete WMC tasks and perform several reading tasks, followed by a reading comprehension test. Participants were sporadically probed during the reading tasks and asked to indicate whether they had been mind wandering. In line with the executive failure hypothesis, the authors found that higher WMC participants reported fewer TUTs. Also, results indicated that there was a significant direct effect of WMC on reading comprehension and a significant indirect effect of WMC on reading comprehension through TUTs, suggesting that mind wandering partially mediated the relation between WMC and reading comprehension. In other words, college students with lower WMC engaged in more mind wandering, which resulted in poorer reading comprehension. Furthermore, McVay and Kane (2012a) provided converging evidence for the executive failure hypothesis by examining mind wandering during the SART.

The decoupling hypothesis. Attention is said to be coupled to perception when the focus of attention is on incoming perceptual stimuli (Smallwood, 2011). The decoupling hypothesis suggests that when the mind wanders, attention is decoupled from perception (Schooler et al., 2011; Smallwood & Schooler, 2006). Based on the assumption that task-related thoughts and TUTs require the same domain general processes, i.e., executive control (Smallwood, 2011), the decoupling hypothesis suggests that mind wandering represents a state of decoupling in which attentional resources are mainly allocated to the processing of TUTs, leading to superficial representations of perceptual information. As a result, according to the decoupling hypothesis, mind wandering leads to shallow processing of external

stimuli and results in performance decrements on the primary task (Schooler et al., 2011; Smallwood, 2011).

The disruptive effect of mind wandering on primary task performance has been documented across various tasks requiring different levels of engagement with the environment (Smallwood, Fishman, & Schooler, 2007). In tasks involving superficial engagement with the external stimuli, such as a perceptual signal detection task, participants are asked to note the occurrence of a target amid nontargets. Although signal detection tasks, in which participants respond to targets and withhold response to nontargets, require only a superficial level of attentiveness to the external stimuli, performance on these tasks is adversely affected when the mind wanders (Giambra, 1995; Smallwood et al., 2004). Likewise, mind wandering has been associated with poorer performance on word list learning tasks (Smallwood, Baracaia, Lowe, & Obonsawin, 2003), which involve a moderate level of engagement with the external environment as participants need to encode single words for later retrieval. Furthermore, it has been shown that mind wandering during a reading task, which requires a deeper level of engagement with the external environment (i.e., text), leads to poorer comprehension of reading material (Smallwood, McSpadden, & Schooler, 2008).

Further evidence for the decoupling hypothesis comes from studies investigating the relationship between mind wandering and cortical response to perceptual information. Event-related potentials (ERPs), derived from EEG, are used as a measure of cortical response to external stimuli, and greater amplitudes in ERPs are linked to increased

attention to external stimuli (Dehaene, Posner, & Tucker, 1994). Specifically, the P300 component of ERPs is used as an index of the processing of task-relevant information.

In three experiments, Kam et al. (2011) investigated the effects of fluctuations in attention to an external task on sensory responses in visual cortex as a function of whether attention was directed to task-related thoughts or TUTs. During a simple visual discrimination task, participants were intermittently probed and asked to indicate whether they were engaged in task-related thoughts or TUTs. Kam et al. (2011) found a greater reduction in the amplitude of ERPs during states of TUTs, or mind wandering, when compared to states of task-related thoughts. Moreover, results also revealed that the occurrence of TUTs was accompanied by attenuation in both visual and auditory sensory responses in cortex, suggesting that the dampening effect of mind wandering on the processing of perceptual stimuli is cross-modal. Similarly, another study provided further support for the reduction in the amplitude of the P300 component during the periods of mind wandering as marked by the SART (Smallwood, Beach, Schooler, & Handy, 2008).

Smallwood et al. (2011) also examined the relationship between mind wandering and changes in pupil diameter during a choice reaction task. When participants were engaged in task-related thoughts, there was a transient increase in pupil diameter in response to external stimuli. By contrast, pupil diameter demonstrated a reduced amplitude of change during states of TUTs, providing further support for the decoupling hypothesis that mind wandering has a dampening effect on the processing of incoming perceptual information.

The meta-awareness hypothesis. The meta-awareness hypothesis capitalizes on the distinction between consciousness, which refers to experiential awareness of “having an

experience” (Schooler, 2002, p. 339), and meta-consciousness, or meta-awareness, which is defined as “one’s explicit knowledge of the current contents of thought” (Schooler et al., 2011, p. 321). Meta-awareness involves an assessment of the contents of one’s thought through interpretation, description or characterization of re-representation of consciousness (Schooler, 2002). For instance, an individual can be experientially aware that he or she is reading a book, but the direction of meta-awareness toward the phenomenal experience of reading is necessary for the individual to realize whether the contents of her or his thought are related to the book or something else. In other words, the individual needs to assess the contents of his or her thought, which may result in a recognition that he or she is totally engaged in reading, or that he or she is thinking about something else other than what he or she is gazing over.

The central premise of the meta-awareness hypothesis is that the capacity to appraise the contents of thought (i.e., meta-awareness) enables individuals to detect any discrepancy between the current thought content and the desired state of consciousness (Schooler et al., 2011). When the mind wanders, meta-awareness serves as a “higher-level explicit monitoring process to take stock of the specific contents of thought and alert one to the fact that they have wandered off task.” (Winkielman & Schooler, 2008, p. 62). Therefore, meta-awareness is pivotal in the regulation of mind wandering episodes and their influence on task performance (Smallwood & Schooler, 2006).

The meta-awareness account of mind wandering differentiates between two types of mind wandering: mind wandering with awareness and mind wandering without awareness. The distinction between these two types of mind wandering is revealed by the combination

of the probe-caught method and self-caught method. During an ongoing task, self-caught mind wandering episodes reflect mind wandering episodes of which participants are aware, because they can consciously report that they have been mind wandering only when they are aware that they are engaged in TUTs. When participants indicate that they have been mind wandering in response to a probe, the interpretation is that they were not aware that they had been engaged in TUTs before being probed. Therefore, probe-caught mind wandering episodes are categorized as mind wandering episodes without awareness, or unaware mind wandering episodes. Otherwise, they would have reported that they had been mind wandering by pressing the designated key before the probe appeared.

The meta-awareness hypothesis posits that mind wandering episodes in the absence of awareness, termed zoning out, have more disruptive effects on task performance compared to mind wandering episodes with awareness, termed tuning out. Previous studies investigating the relationship between meta-awareness and mind wandering during reading have shown that individuals often lack awareness of mind wandering, and that the effects of mind wandering on text comprehension are more disruptive when participants lack explicit awareness of mind wandering than when they are aware they have been mind wandering (Schooler et al., 2005; Smallwood et al., 2008). Mind wandering without awareness was also linked to poorer performance on the SART (Smallwood et al., 2007).

Other studies have examined the influence of interventions that reduce meta-awareness on mind wandering. Sayette et al. (2009) investigated how alcohol intoxication affected self-caught and probe-caught mind wandering episodes during reading. The participants in the experimental group were given an alcoholic beverage while the

participants in the control group were given a placebo beverage that they were led to think contained alcohol. After the manipulation, participants started reading some excerpts from *War and Peace*. During the reading task, participants were asked to press a key whenever they noticed they had been mind wandering, or zoning out. They were also sporadically probed and asked to report whether or not they had been mind wandering. Based on the results of the study, inebriation had different effects on self-caught and probe-caught mind wandering episodes. Participants who drank the alcoholic beverage mind wandered without awareness more than twice as often as sober participants. However, there was no statistically significant difference in self-caught mind wandering episodes across the two groups. Although inebriated participants mind wandered more and thus had more opportunities to catch themselves, they were no more likely to catch themselves mind wandering than the participants in the placebo group, which led the authors to conclude that inebriation impaired participants' ability to assess the contents of their thought and thus to notice that they had been mind wandering.

In a similar study, Sayette, Schooler, and Reichle (2010) examined the effect of cigarette craving on meta-awareness of mind wandering during reading. This study used the same methodology as the Sayette et al. (2009) study, but the participants were smokers, who were divided into a crave condition and a low-crave condition. Nicotine deprivation was induced on the participants in the crave condition by asking them to stop smoking at least 6 hours before the experiment. Results showed that craving had a profound influence on meta-awareness of mind wandering: Participants in the crave condition mind wandered without awareness more than three times as often as low-crave participants; however, the two

groups did not differ in their propensity to spontaneously notice the occurrence of mind wandering, suggesting that craving impaired participants' meta-awareness of mind wandering. Taken together, findings from these two studies indicate that interventions reducing meta-awareness increase the likelihood of mind wandering while decreasing the likelihood of noticing such occurrences. Based on the meta-awareness hypothesis, then, it could be hypothesized that interventions that increase meta-awareness, like mindfulness meditation training, should decrease the likelihood of mind wandering and increase the likelihood of noticing such occurrences.

Reconciling the four hypotheses: The process-occurrence framework

While these four theoretical explanations seem to provide relatively different explanations for mind wandering, they are not mutually exclusive. Rather, they actually attempt to explain the same phenomenon focusing on distinct elements of mind wandering. The four theoretical explanations can be reconciled based on Smallwood's (2013) process-occurrence framework. The process-occurrence framework provides a distinction between how mind wandering occurs and what happens after the onset of mind wandering. The current concerns hypothesis, the executive failure hypothesis, and meta-awareness hypothesis each provide an explanation for a different mechanism involved in the occurrence of mind wandering (activation of salient information for the current concerns hypothesis, failure in executive control for the executive control hypothesis, and lapses in higher-order monitoring of the contents of conscious thought for the meta-awareness hypothesis), whereas the decoupling hypothesis provides an explanation for processes supporting the continuity of an internal train of thought after its occurrence.

The process-occurrence framework suggests that these four different mechanisms may be involved in different times when the mind wanders. Given that current concerns are always present, either at a conscious level or unconscious level (Klinger, 1999, 2013; McVay & Kane, 2010), they are present even when attentional resources are allocated to external stimuli. Therefore, at a moment in which the focus of attention is on incoming perceptual information, current concerns are not salient. As the focus of attention starts to wane, attention to external input gradually decreases while the representations of current concerns start to become increasingly salient. At a point when current concerns and external input are equally represented in working memory, if executive control fails to suppress these TUTs associated with current concerns and/or the individual is intermittently unaware that the focus of attention is not on incoming perceptual information, current concerns intrude into consciousness and start to gain dominance over external stimuli. Thus, the focus of attention becomes TUTs and attention to external stimuli continues to diminish. When the focus of attention is on TUTs, mental representations of TUTs are prioritized, processed and maintained in working memory, leaving little processing capacity for incoming perceptual information. This state of mind wandering can perpetuate until meta-awareness is reinstated and the individual is alerted that the current contents of conscious thought are not related to the ongoing task, or until executive control is reactively initiated to redirect attentional resources to the processing of external input. Alternatively, the individual may be engaged in TUTs until perceptual information drastically changes (e.g., sudden changes in the environment, high pitch sound, or a car crash during a movie). In either case, all the alternative accounts predicated by different hypotheses can be said to require the

redirection of the focus of attention to incoming perceptual information. Accordingly, as attentional resources are redirected to external stimuli, executive control is reinstated to suppress TUTs, preventing them from intruding back to consciousness. Consequently, the focus of attention is switched back to external input, and thus, mental representations of incoming perceptual information are encoded, processed and maintained in working memory.

Because these accounts offer slightly different explanations for cognitive processes involved in mind wandering, the literature has witnessed a lively scholarly debate among the leading researchers in the field. For instance, the executive failure account has been contrasted with the decoupling hypothesis (McVay & Kane, 2009, 2010). The decoupling hypothesis's view that executive resources are used during mind wandering has been challenged by the executive failure hypothesis on the grounds that mind wandering reflects a failure in executive control and that individuals with more executive resources (high WMC) are no more likely to mind wander than those with less executive resources at their disposal (McVay & Kane, 2009). These two arguments can be reconciled based on the process-occurrence framework: the decoupling hypothesis is concerned with processes that can support the continuity of TUTs after the occurrence of mind wandering and the executive failure hypothesis taps into how mind wandering is initiated. Thus, the decoupling hypothesis provides an explanation complementary, rather than competing, to the executive failure hypothesis.

Regarding the role of executive control in mind wandering, previous studies have shown a negative association between executive control capabilities and propensity for

mind wandering in demanding tasks (Brewin & Smart, 2005; Geraerts, Merckelbach, Jelicic, & Habets, 2007). Specifically, individuals with a high WMC tend to have fewer mind wandering episodes during sustained attention tasks and reading (McVay & Kane, 2009, 2010; Unsworth & McMillan, 2013). This is, however, not the case for nondemanding conditions (Levinson, Smallwood, & Davidson, 2012; Rummel & Boywitt, 2014). When task demands are relatively low or the task is automated to some degree, individuals with high WMC tend to have more TUTs. While the executive failure hypothesis could explain the former finding that there exists a negative association between executive control capabilities and propensity for mind wandering in demanding tasks, it falls short of explaining the positive relationship between WMC and mind wandering in nondemanding conditions. Likewise, the executive resource-competition view inherent in the decoupling hypothesis (Smallwood & Schooler, 2006) fails to account for the regulatory influence of executive control on mind wandering. Based on the process-occurrence framework, it is plausible that executive control can regulate mind wandering in resource demanding tasks. However, it can also contribute to the continuity of mind wandering episodes after the onset of TUTs when task demands are low. This has come to be known as the *context regulation hypothesis* (Smallwood & Schooler, 2015), which suggests that the role of executive control in mind wandering changes depending on task demands. Thus, based on the context regulation hypothesis (Smallwood & Schooler, 2015), individuals demonstrate greater propensity to mind wander in nondemanding tasks, relative to demanding tasks, and mind wandering leads to poorer performance in tasks that require sustained attention such as reading and listening to lectures, compared to tasks with low demands.

Mind wandering in educational settings

Experience sampling studies demonstrate that mind wandering is prevalent and frequent in everyday life (Killingsworth & Gilbert, 2010; McVay, Kane, & Kwapil, 2009). Mind wandering also occurs in educational contexts (Bunce, Flens, & Neiles, 2010; Lindquist & McLean, 2011; Szpunar, Moulton, & Schacter, 2013). In one of the early studies into mind wandering during lectures, Cameron and Giuntoli (1972) probed college students at ten randomly chosen times during lectures. Students were asked to report what they were thinking about, whether they were listening to the instructor and whether their listening was superficial or active. Results indicated that more than half of the students had attentional lapses during lectures, with approximately 40-46% of students paying attention at any given moment during lectures. Similarly, Stuart and Rutherford (1978) asked medical students to report their concentration level across twelve 50-minute lectures. Students were probed at 5-min intervals during the lecture with a buzzer. According to the results of the study, the level of concentration reached its pinnacle between 10 and 15 minutes from the class start time, accompanied by a substantial decrease in student attention afterwards.

Geerligs (1995) used experience sampling to examine whether students were engaged in task-related thoughts or TUTs during problem-based small group discussions. During the group discussion, students were auditorily probed and asked to report the content of their thoughts, which were then classified as either task-related thoughts or TUTs. The author found that the prevalence of TUTs was 26% during the small group discussions and that these TUTs were mainly related to current concerns about everyday problems. Similarly, a more recent study by Lindquist and McLean (2011) investigated the extent to

which college students mind wandered during lectures. They probed college students at five different times during three psychology lectures lasting 50 minutes and asked them to indicate whether they were having TUTs. On the whole, students reported TUTs for approximately 33% of the probes. Result also showed that TUTs were more common late in the lecture (44%) than early in the lecture (25%). The authors also revealed a negative association between mind wandering and note taking during lectures and retention of lecture content. In other words, compared to students reporting fewer episodes of mind wandering, those students who reported having more TUTs took less detailed notes during the lectures and demonstrated poorer performance on the tests assessing the retention of the lecture content. Taken together, these studies conducted in traditional college lecture environments provide ecologically valid evidence for the prevalence of mind wandering in traditional educational settings, highlighting the importance of studying the occurrence of mind wandering during lectures and finding strategies to curtail its adverse effects on learning and retention.

In addition to the investigation of mind wandering during traditional lectures, several studies have examined mind wandering during lecture videos, which are being increasingly used in online educational settings such as online college classes, massive open online courses (MOOCs), and flipped classrooms (Szpunar et al., 2013). To investigate the relationship between time on task and mind wandering during lecture videos, Risko et al. (2012) conducted two experiments in which college students were asked to watch a one-hour lecture video either alone (Experiment 1) or with other students in a classroom environment (Experiment 2), and they were intermittently probed to report on their

thoughts – specifically 5, 25, 40 and 55 minutes into the lecture. In both experiments, three one-hour lectures on psychology, economics, and classics were used and participants in each experiment were divided into three groups with each watching the lecture video on one of the three topics. Having watched the lecture video, students were tested on their retention of the content of the lecture video.

Sixty students participated in Experiment 1 and watched the lecture videos in a laboratory setting. They reported mind wandering in response to 43% of the probes. Results from Experiment 1 revealed that episodes of mind wandering increased in the second half of the lecture video (52%) compared to the first half (35%). Furthermore, results also revealed a negative association between mind wandering and performance on the retention test such that students reporting more mind wandering episodes demonstrated poorer performance on the test. Moreover, the increased episodes of mind wandering in the second half of the lecture video were associated with poorer performance on the test questions pertaining to the second half of the lecture video when compared to the test questions related to the first half of the lecture video. Experiment 2 was a replication of Experiment 1 with minor changes to when the probes were given and the number of questions in the retention test as well as the setting. The results obtained from Experiment 2 were similar to the results from Experiment 1: mind wandering and the associated reduction in memory for the content of lecture video increased as a function of time spent watching the lecture video. Risko et al. (2012) noted that students tended to have more episodes of mind wandering toward the end of a lecture video and that those students who reported more mind wandering tended to have a lower score on a retention test assessing the comprehension of the lecture video. Two

other studies (Farley et al., 2013; Risko et al., 2013) provided further evidence for this relationship between mind wandering and time on task and its effect on the retention of lecture video content.

In an attempt to determine what might alleviate mind wandering during lecture videos, Szpunar et al. (2013) looked at the effects of interpolating memory tests into lecture videos and conducted two experiments in which college students watched a 21-min lecture video on introductory statistics. The video consisted of four segments. In Experiment 1, there were two groups, the tested-group and non-tested group. A third group, the restudy group, was added in Experiment 2. In Experiment 1, participants were asked to rate from one to seven how much they mind wandered after each lecture segment and before the final test. In Experiment 2, students were intermittently probed and asked to indicate whether they were mind wandering. Following each segment of the lecture video, students were asked to spend approximately one minute completing some basic arithmetic problems that were irrelevant to the lecture video. After the arithmetic problems, students in the tested group completed short tests on each segment, and students in the non-tested and restudy groups were not given a test for the segments. Those in the restudy group were reshown the lecture material from the segment corresponding to the material on which the tested group was given a test. All participants took a final test on the entire video.

Szpunar et al. (2013) found that compared with the non-tested (both in Experiment 1 and Experiment 2) and restudy groups (Experiment 2), the tested group reported fewer episodes of mind wandering, took more notes during the lecture, and performed better on the final test. Results revealed no significant differences among the non-tested and restudy

groups in Experiment 2 in terms of the frequency of mind wandering, note taking, and performance on the final test. These results suggest that interpolated memory tests can reduce mind wandering during lecture videos and engage students in task-related activities (e.g., note taking) while they are learning from lecture videos.

Taken together, the studies reviewed hitherto demonstrate the prevalence of mind wandering in educational settings and shed light on its detrimental effects on learning and retention. When learning from lecture videos, learners need to focus their attention on the content of the lecture, sustain it throughout the video, and suppress external or internal interference at the same time (Schacter & Szpunar, 2015). Therefore, it is important to determine what might help to minimize the occurrence of mind wandering during lectures and thereby facilitate learning for students.

Mindfulness

Mindfulness, an English translation for the Pali word *sati* (Gethin, 2011), is a technical word in Buddhism that has been attributed multiple meanings including attention, awareness, retention, and discernment (Davidson & Kaszniak, 2015). In a recent review on the definitions of mindfulness, Bodhi (2011) noted that mindfulness refers to a family of contemplative principles and practices that guide individuals in their journey to happiness and that lead to the extinction of suffering and sorrow. In its simplest form, mindfulness entails reflexively contemplating one's own experience, embodied within the body, feelings, states of mind, and experiential phenomena. Mindfulness has a long history, rich in philosophical discussions. In what follows, however, mindfulness is examined in terms of a contemporary conceptualization, in which it is divorced from religious roots.

Mindfulness has been a topic of empirical research since its introduction in 1979 as a stress reduction intervention by Jon Kabat-Zinn in his Mindfulness-Based Stress Reduction (MBSR) program (Bodhi, 2011). Since then, there has been an increasing scholarly interest in its nonsectarian applications for empirical research in mainstream psychology (Davidson & Kaszniak, 2015). In contemporary psychology, mindfulness is conceptualized as a reflexive approach to cultivate increased awareness (Bishop et al., 2004).

Multiple definitions of mindfulness have been proposed by researchers in the field. One often cited definition is that mindfulness is “an openhearted, moment-to-moment, nonjudgmental awareness” (Kabat-Zinn, 2005, p. 24). Although there is no exact consensus in the mindfulness literature regarding what mindfulness fully entails (Grossman & VanDam, 2011), there are two main approaches to operationalizing mindfulness as a construct of interest for empirical research in psychology. One approach defines mindfulness as a mental state of sustained attention to and conscious awareness of the present moment (Brown & Ryan, 2003). The other approach operationalizes mindfulness as a two-component construct including self-regulation of attention, which is analogous to the former operational definition’s focus on sustained attention to the present moment, and an orientation toward one’s own experiences that is characterized by curiosity, openness and acceptance (Bishop et al., 2004). Despite nuances between the two operational definitions, for purposes of this research mindfulness can be thought of as increased awareness of and sustained attentiveness to the present moment or the here and now.

Attention and mindfulness

According to Bishop et al. (2004), mindfulness involves the self-regulation of attention by dispassionately observing and attending to one's thoughts, feelings, and sensations at the present moment. This sustained attentiveness to the present moment or the here and now is associated with improvements in sustained attention, switching attention, and inhibiting elaborative processing of thoughts and feelings to which the mind wanders.

One of the basic tenets of mindfulness meditation training (MMT) is that paying attention to and being aware of one's thoughts, feelings, sensations, as well as one's surroundings are innate capabilities and the cultivation of mindfulness by putting these resources into use when appropriate is a learnable skill (Kabat-Zinn, 1994). Some mindfulness meditation practices entail focusing on a single experience (e.g., the breath), while other practices are geared toward broadening the attentional field without selectively focusing on a single object but instead openly monitoring one's immediate experience (Bodhi, 2011; Davidson & Kaszniak, 2015). To provide further insight into these different styles of meditation, Lutz, Slagter, Dunne, and Davidson (2008) proposed a theoretical framework that distinguishes between focused attention and open monitoring meditative practices.

In this framework, focused attention meditation involves deliberately directing and sustaining attention on a specific object (e.g., the breath). The practice also entails detecting when the mind wanders to thoughts, feelings, or sensations unrelated to the chosen object (e.g., how little time one has to prepare for an upcoming final oral exam). When mind

wandering is detected, the meditator disengages attention from the distracting thought, feeling, or sensation and shifts attention back to the chosen object, which is usually accompanied by cognitive reappraisal of the distracting thought, feeling, or sensation. Based on supportive evidence from neuroimaging studies, Lutz et al. (2008) argued that focused attention meditation training not only helps to cultivate sustained attentiveness to immediate experience, but it also enhances the development of the abilities to monitor distractions while keeping the attention focused on the chosen activity, to disengage attention from a thought, feeling, or sensation unrelated to the object of focus, and to shift the focus of attention back to the chosen object.

Open monitoring meditation entails no voluntary focus on a specific object, but instead monitoring the changing contents of experience, whether it be thoughts, feelings, or sensations (Lutz et al., 2008). Open monitoring meditation, based on Lutz et al.'s description, involves maintaining nonreactive awareness of thoughts, feelings, or sensations arising in consciousness. It also entails maintaining an openness to automatic processing of incoming perceptual information. Open monitoring practice is aimed at the recognition of the nature of cognitive-emotional patterns arising in the stream of consciousness during various experiences without reactively being involved in such experiences. Thus, open monitoring meditation practice cultivates meta-awareness of the present moment, capitalizing on the self-monitoring and sustained attention skills initially developed through focused attention meditation (Davidson & Kaszniak, 2015).

Effects of mindfulness training on attention

The benefits of MMT for improving attentional control and executive functioning have been well documented. For instance, using a pretest-posttest design, Heeren, Van Boreck and Philippot (2009) investigated the effects of Mindfulness-Based Cognitive Therapy (MBCT) on cognitive inhibition and motor inhibition. The MBCT intervention was an eight-week program and participants completed the same measures before and after the intervention. Participants' cognitive inhibition capacity was measured by their performance on the Hayling Task, an executive functioning test in which participants listen to two sets of 15 sentences and are asked to complete each sentence with an appropriate or unrelated word, depending on the set. Two dependent measures from the Hayling task were used to assess their performance on the task: response latency (i.e., the amount of time that has elapsed from the pronunciation of last word to when the participant began to respond) and error rate. Also, participants' ability to inhibit motor behavior was assessed using a go/no-go task, in which randomly-generated five-digit numbers were shown for 500ms followed by a blank screen for 1500ms. Half of the five-digit numbers were targets consisting of identical matching numbers (e.g., 11111) and other half were nontargets consisting of random non-matches (e.g., 32415). Half of the targets were programmed to turn from black to red at 50- to 350-ms intervals after being presented on the screen, which was the no-go signal. Participants were asked to respond to identical matching numbers unless they turned red. Results showed that the participants in the mindfulness intervention group, whose performance on the Hayling task was comparable to that of the participants in the matched control groups before the intervention, had significantly fewer errors in the Hayling task

after the MBCT intervention. Further analysis showed that the increase in the rate of correct responses from pretest to posttest measures was not due to the changes in reaction time. However, there were no significant differences in participants' performance on the go/no-go task before and after the intervention. Based on these results, Heeren et al. (2009) noted that mindfulness training increased the capacity for cognitive inhibition but not for motor inhibition.

In a longitudinal study, Sahdra et al. (2011) investigated the effects of MMT on attentional control as assessed with a response inhibition task (RIT). There were two three-month retreats, during which participants in the mindfulness training group practiced mindfulness meditation for six to ten hours a day under the guidance of an experienced mindfulness meditation trainer in an isolated retreat setting. In Retreat 1, there was a retreat group that received the MMT and a wait-list control group. In Retreat 2, participants in the wait-list control group from Retreat 1 underwent the same three-month mindfulness training. Participants completed various tasks, including the RIT, before, during (half way through) and after the three-month retreat. Also, there was a follow-up assessment occurring approximately five months after each retreat. Results indicated that the retreat group in Retreat 1 demonstrated better performance on the RIT when compared to the wait-list control group. The same effect was observed when the control group underwent the identical MMT in Retreat 2. Follow-up assessments demonstrated that the improvements in RIT performance, and thus in attentional control, were sustained five months after the completion of the three-month MMT.

Jha et al. (2010) examined the influence of MMT on WMC, specifically on the OSPAN performance, among a pre-deployment military cohort receiving mindfulness training, a pre-deployment military control group, and a civilian control group. The mindfulness training cohort underwent an eight-week mindfulness training, while the other two groups were only contacted to complete the study measures. All groups completed the OSPAN task before and after the intervention. Results showed that there was no significant change in the civilian control group's performance on the OSPAN task and that the performance of the military control group on the OSPAN task degraded over time. Performance degradation on the OSPAN task was also observed in those participants in the mindfulness training group who reported spending little time practicing mindfulness meditation. Participants in the mindfulness training group with high levels of practice demonstrated performance improvements on the OSPAN task after the intervention when compared to their OSPAN score prior to the intervention. Further analysis revealed that increased daily mindfulness meditation practice time corresponded to increased performance on the OSPAN task after the intervention. Thus, Jha et al. (2010) noted that mindfulness meditation practice may be a protective factor for degradation of WMC due to pre-deployment-related factors, such as stress.

Zeidan, Johnson, Diamon, David, and Goolkasian (2010) investigated the effects of a short-term, four-day MMT on working memory and sustained attention, as indexed by an automated letter N-back task, in which participants are shown an array of letters and are asked to respond by pressing a designated key when a current probe letter on the screen is the same as the letter shown two items back. When the current probe letter is different from

the letter presented two items back, participants withhold respond and do not press the designated key. College students were randomly assigned to a mindfulness training group, which met for two hours a day during the course of the four-day program, and a listening control group. Participants in the listening group listened to the recorded audiobook of J. R. R. Tolkien's *The Hobbit* during the four two-hour sessions. All participants completed the measures before and after the intervention. Results showed that there were no differences between the two groups on the number of correct responses, N-back accuracy. However, the MMT group, compared to the control group, demonstrated improved performance on the extended hit runs, which represent the number of correct responses in a row. Based on these results, the authors concluded that the short-term MMT intervention improved sustained attention such that students in the MMT group were better able to maintain sustained accuracy on the N-back task. Findings from this study suggest that short MMT interventions may not necessarily lead to improvements in working memory per se, but may improve individuals' ability to sustain attention.

Jha, Krompinger and Baime (2007) examined the effects of MMT on specific attentional subsystems (i.e., alerting, orienting, and conflict monitoring) using the Attention Network Task (ANT; Fan, McCandliss, Sommer, Raz, & Posner, 2002). Alerting involves maintaining vigilance or alertness, orienting involves directing attention to specific stimuli and conflict monitoring involves prioritizing among tasks and responses that compete with each other. During the ANT, participants look at a central fixation point on the screen and complete several trials in which they respond to the presentation of a target by clicking the mouse keys. Each trial begins by the presentation of the central fixation and then a cue is

presented for 100ms, followed by a 400ms delay interval. Afterwards, a target is presented 1.068° above or below the central fixation. The target stimuli consist of a row of five arrows and are displayed until a response has been made or for 1700ms (whichever is earlier). Participants are asked to determine whether the arrow in the center of the row is pointed to the left or right while fixating on the central point. In congruent trials, the arrows to the left and right of the center arrow point in the same direction as the center arrow (e.g., →→→→→) and in other trials those arrows point in the opposite direction (e.g., ←←→←←). Before each target is presented, one of the four cue trials is presented: no-cue trials (only a target appears), double-cue trials (an asterisk appears below and above the central fixation to signal the presentation of the subsequent target), center-cue trials (an asterisk appears at the central fixation as a warning for the upcoming target), and spatial-cue trials (an asterisk appears either below or above the central fixation to signal where the target will appear). These four cue trials differ in the temporal and spatial information they convey regarding the upcoming target. No-cue trials give no temporal or spatial warning about when and where the target, the arrows, will appear. Double-cue and center-cue trials provide only temporal information about the upcoming target. Spatial-cue trials signal not only when the target will appear, but where it will appear as well.

Jha et al. (2007) assigned medical and nursing students, who had no prior experience with mindfulness meditation practices, to an eight-week MBSR program. There was a control group consisting of students naïve to mindfulness meditation that was exposed to no mindfulness intervention. All participants completed the ANT before and after the intervention. Initially, before the onset of the intervention, there were no differences in

participants' performance on the ANT between the MBSR and control groups. Results revealed that the participants in the MBSR group demonstrated improvements only in their orienting performance. This suggests that the MBSR program improved participants' ability to direct and limit attention to a specific input or selected object, which is a fundamental skill that focused mindfulness meditation training aims to cultivate through repeated shifting of attention back to the chosen object of focus (e.g., one's breathing) when attention strays off to other thoughts, feelings, or sensations (Lutz et al., 2008). Yet, there were no differences in participants' alerting performance and conflict monitoring performance between the two groups after the intervention. The fact that the MBSR group was not different from the control group in conflict monitoring scores may be surprising given the documented causal association between meditation and improvements in conflict monitoring (Wenk-Sormaz, 2005). However, this may be, at least partly, due to the unexpected increase in conflict monitoring scores of the participants in the control group from Time 1 to Time 2, even though they did not have any attention training. The authors attributed this to a potential vulnerability of the ANT to task exposure effects for the conflict monitoring component. Also, one potential explanation for why the two groups did not differ in their alerting scores may be that improvements in the alerting aspect of attention, which is characterized by vigilance and alertness to changes in the environment, may be more amenable to open monitoring meditations and thus require longer-term experiences with mindfulness meditation practices (Lutz et al., 2008).

Allen et al. (2012) investigated the influence of a six-week mindfulness training program on cognitive control and executive functioning in novice meditators. They

compared a mindfulness meditation group, which participated in a weekly two-hour guided meditation session for six weeks, and an active control group, which met and listened to the reading of a book by a facilitator, on their performance on an affective Stroop task before and after the intervention. Participants completed the affective Stroop task while being scanned using fMRI, a brain imaging technique used to capture the BOLD activation levels in brain regions. The affective Stroop task was used as a test of cognitive control and conflict resolution. The affective Stroop task involved a number counting task consisting of 360 trials, each of which included the successive presentation of a central fixation point, a first number display, a first picture display, a second number display, a second picture display, and a final blank stimulus. The number counting task required participants to indicate which of the two number displays had greater numerosity (i.e., which display contained more numbers). Response conflict originated from incongruence between the Arabic numeral and the numerosity of the display. Congruent trials were those trials in which the Arabic numeral was consistent with the numerosity of the display (e.g., two 2s and four 4s), whereas incongruent trials were those trials in which the Arabic numeral was inconsistent with the numerosity of the display (e.g., two 4s and four 2s). The interleaved affective images were used as distractors and interfered with the performance on the number counting Stroop task by requiring additional bottom-up affective processing. An individual's performance on the affective Stroop task indicated how well the individual could suppress response conflict, which referred to the simultaneous activation of incongruent, countervailing responses (Arabic numeral vs. numerosity).

The comparison of the participants' performance on the affective Stroop task revealed that only the MMT group demonstrated reduced response conflict over time, suggesting improvement in interference suppression. The fMRI results showed that, relative to the active control group, the participants in the mindfulness group had significantly higher levels of BOLD activation levels in the dorsolateral prefrontal cortex – a brain region that is mostly implicated in top-down attentional control and executive functioning (Seeley et al., 2007). This suggests that the recruitment of the dorsolateral prefrontal cortex during the conflict resolution task was greater for the MMT group than the active control group. Also, two other studies have provided further evidence for the beneficial effects of MMT on Stroop task performance for experienced meditators relative to non-meditators (Moore & Malinowski, 2009; Teper & Inzlicht, 2013).

The observed behavioral effects of MMT on attentional control and executive functioning have been linked to changes in the neural underpinnings of these cognitive mechanisms (Allan et al., 2012; Hölzel et al., 2007; Tang & Posner, 2013; Treadway & Lazer, 2010). Specifically, studies have shown an increase in the activation of the anterior cingulate cortex (ACC), which has been implicated in directing attention and detecting conflicting information (van Veen & Carter, 2002). Increased activity in the ACC is attributed to the exertion of a top-down control to maintain attention on a target in the presence of external distractions or trains of thought conflicting with immediate task goals (van Veen & Carter, 2002). Hölzel et al. (2007) showed that experienced meditators had greater activity in the rostral ACC during mindfulness meditation when compared to nonmeditators. Similarly, Gard et al. (2012) found greater activity in the rostral ACC when experienced mindfulness

meditators practiced mindfulness meditation, compared to the control group, providing further credence to the effect of mindfulness meditation on ACC activity. Additionally, findings from structural MRI studies provide evidence for structural changes in the ACC attributable to meditation practice (Grant, Courtemanche, Duerden, Duncan, & Rainville, 2010; Tang et al., 2010).

Together, these findings suggest that MMT could enhance attentional control and executive functioning and that brain regions associated with these mechanisms are highly recruited and demonstrate concomitant structural changes as a result of consistent practice. During mindfulness meditation, individuals regulate attention by selecting and focusing on a specific object and redirecting attention back to the chosen object when attention drifts off to other thoughts, feelings, or sensations. Attention regulation is commonly practiced and developed in early phases of MMT, which are mostly related to the development of focused attention. In the subsequent phases of MMT, individuals are more engaged in open monitoring practices, observing internal and external stimuli, which can contribute to the cultivation of unfocused sustained attention and increased awareness (Chiesa, Calati, & Serretti, 2011).

Recent meta-analytic reviews (Sedlmeier, Eberth, Schwarz, Zimmermann, & Haarig, 2012; Zoogman, Goldberg, Hoyt, & Miller, 2015) have reported moderate effect sizes for the effects of mindfulness interventions (mainly long-term interventions) on attention-related dependent variables ($\bar{r} = .32$ in Sedlmeier et al. and $d_{el} = .28$ in Zoogman et al.). This indicates that these mindfulness interventions lead to substantial improvements in attention-related outcomes. While previous studies have provided converging evidence for the benefits of

long-term MMT interventions (lasting from several weeks to months), these studies necessitate the investment of a considerable amount of time, financial resources and preparation, making it harder to investigate the effects of MMT in diverse settings for many researchers. Therefore, it is useful to explore whether brief MMT interventions, which involve participants engaging in a single mindfulness meditation practice for a short period of time (5-20 minutes), can yield positive outcomes similar to those obtained from long-term mindfulness-based interventions (Zeidan et al., 2010). Experimental manipulations aimed at inducing a state of mindfulness do not attempt to replicate the long-term benefits of MMT, but instead are being used to examine the short-term effects of brief mindfulness meditation practices on certain dependent variables conceptually linked to mindfulness (Williams, 2010). Therefore, although such brief interventions may not provide as robust benefits as long-term interventions, these investigations can provide invaluable insight into immediate benefits of brief MMT and its application to various domains, including interpersonal relationships, daily life settings, work environments, education, etc.

Mindfulness and mind wandering

Recognizing the potential of MMT as a means of enhancing one's attentional control and executive functioning abilities as well as increasing one's awareness of the present moment, researchers have proposed mindfulness as an antidote for mind wandering and have become interested in its effects on mind wandering (Mooneyham & Schooler, 2013; Mrazek et al., 2012). For instance, Mrazek et al. (2012) reported two studies investigating the relationship between mindfulness and mind wandering. Study 1 was aimed at disentangling the association between the Mindful Attention Awareness Scale (MAAS),

which is a commonly used measure of dispositional mindfulness, and several measures of mind wandering. Results from Study 1 showed that high levels of mindfulness, as measured by the MAAS, were associated with fewer episodes of mind wandering. While Study 1 provided evidence for the notion that mindfulness and mind wandering are opposing constructs, the generalizability of the results were limited by the correlational design of the study. In Study 2, therefore, the authors set out to examine the effects of an induced short-term mindfulness state on mind wandering. Specifically, they were interested in whether a brief (8-minute) mindful breathing exercise could attenuate mind wandering. There were three groups, namely mindful breathing, passive relaxation, and reading. All participants completed the same SART before and after the manipulation. Compared to the participants in the passive relaxation and reading groups, participants in the mindful breathing group had fewer SART errors and lower RT variability, which have been associated with reduced TUTs. Mrazek et al. concluded that a brief 8-minute mindfulness practice could reduce mind wandering during a sustained attention task.

Building on the previous study, Mrazek, Franklin, Phillips, Baird and Schooler (2013) investigated the effects of a two-week mindfulness training program on mind wandering and cognitive performance. College students were randomly assigned to either a mindfulness training program or a nutrition program. In the mindfulness program, students were trained on strategies to improve sustained attentiveness to the here and now and they were asked to practice a 10-minute mindfulness meditation in their everyday life during the course of the two-week training program. The authors found that students in the mindfulness training program mind wandered less frequently than those in the nutrition program during the

reading task. Also, results revealed that the mindfulness training group demonstrated significantly better improvement in the WMC task and reading comprehension test used in the study, and that this improvement was partially mediated by a decrease in mind wandering.

These studies provide converging evidence that MMT can alleviate mind wandering, mitigate its disruptive effects, and improve performance in sustained attention and working memory tasks as well as reading comprehension. The positive effects of mindfulness training on mind wandering open up the possibility that mindfulness training could be used as an intervention to ward off mind wandering in educational settings. However, no studies have investigated this relationship within the context of learning from lectures.

CHAPTER 2. EXPERIMENT 1

Studies reviewed so far demonstrate that mind wandering is a core aspect of one's mental life, that it is prevalent in daily life, and that it is associated with performance decrements on diverse tasks, including sustained attention tasks, reading, and listening to lectures. Given that college students are more likely to mind wander during lectures or while studying than other daily life settings (Unsworth et al., 2012), it is important to examine techniques that might inhibit mind wandering in educational settings and modulate its deleterious effects on learning (Szpunar et al. 2013). In fact, Schacter and Szpunar (2015) and Szpunar et al. (2013) explicitly noted that there is an increasing need for studies that investigate which strategies can be helpful in reducing the extent to which students mind wander during lectures and ameliorate the harmful effects of mind wandering on learning.

In order to address this gap in the literature, the purpose of Experiment 1 was twofold: it was designed to investigate whether inducing a brief mindfulness state prior to a lecture video could reduce mind wandering while learning from the lecture video and it also examined the role of executive control in the relationship between mindfulness and mind wandering. There was a mindfulness meditation group, a listening group that served as an active control group, and a no-treatment control group. Participants in the mindfulness group listened to and practiced a brief guided mindfulness meditation aimed at focusing attention on the present moment by anchoring attention to the breath. In the listening group, participants listened to an audiobook in order to keep them actively listening for the same amount of time as the mindfulness practice. Lastly, the control group listened to no audio material, but instead directly proceeded to the lecture video.

To induce a state of mindfulness through brief interventions, researchers often use guided mindfulness practice (e.g., Erisman & Roemer, 2010; Taraban, Heide, Woollacott, & Chan, 2017; Xu, Purdon, Seli, & Smilek, 2017). In the guided mindfulness practice, participants listen to a guided audio recording that encourages them to focus attention on their breath and bring attention back to the breath whenever they notice they have been mind wandering. The guided audio recording also includes considerable amount of silent moments. In a guided mindfulness practice, participants engage in mindfulness practice while listening to intermittent audio instructions that serve as reminders. Unguided mindfulness practice is sometimes used (e.g., Mrazek et al., 2012). Participants are instructed to focus attention on their breath and bring attention back to the breath whenever they notice they have been mind wandering. The instructions are displayed on a screen and participants practice mindfulness on their own after reading the instructions. Based on the assumption that a guided mindfulness practice would enable participants to engage in the mindfulness practice more thoroughly than an unguided mindfulness practice, a guided mindfulness practice was used in the current dissertation.

Consistent with the meta-awareness hypothesis, it has been shown that interventions that decrease meta-awareness increase the likelihood of mind wandering without awareness and decrease the likelihood of noticing such occurrences (Sayette et al., 2009; Sayette et al., 2010). Given that inducing a mindfulness state should increase one's meta-awareness, participants in the mindfulness group were expected to have fewer zoning outs, or episodes of mind wandering without awareness, than the two control groups. Also, from a perceptual decoupling perspective, because participants in the mindfulness group were

expected to maintain sustained attention on the external task, their comprehension of the lecture material was expected to be better than that of the two control groups.

In addition to the primary hypotheses, Experiment 1 also investigated the roles of various individual difference measures including trait mindfulness, mind wandering tendency or trait mind wandering, media multitasking frequency, and the tendency to have dissociative experiences in the propensity for mind wandering during the lecture video. Trait mindfulness or dispositional mindfulness refers to the extent to which individuals demonstrate characteristics associated with mindfulness in their daily life. Trait mindfulness has been shown to be negatively associated with the propensity for mind wandering (Mrazek, Phillips et al., 2013; Mrazek et al., 2012), suggesting individuals who demonstrate high levels of trait mindfulness tend to mind wander less during demanding tasks. Therefore, it was expected that trait mindfulness would negatively predict the propensity for mind wandering during the lecture video. In the same vein, those with a greater tendency to mind wander in daily life were expected to mind wander more during the lecture video.

Media multitasking refers to concurrently engaging in and consuming multiple types of media (Ophir, Nass, & Wagner, 2009). It has been shown that heavy media multitaskers demonstrate an increased susceptibility to interference from task-irrelevant stimuli during demanding cognitive tasks and that they show poor attentional control in the face of interference (Ophir et al., 2009). Furthermore, based on findings from neuroimaging studies, it could be argued that heavy media multitasking may lead to increased activity in the default mode network (DMN; Ziegler et al., 2015), which is associated with mind wandering (Buckner et al., 2008; Mason et al., 2007). Therefore, it was predicted that

increased media multitasking frequency would predict greater propensity for mind wandering.

Dissociation refers to transient lapses or disruptions in the integration of experiences, thoughts, feelings, memories, and actions into consciousness (Bernstein & Putnam, 1986). Examples of dissociative experiences include listening to someone talk but not hearing part or all of what the person said, getting absorbed in a movie to the extent that one is unaware of what is happening around the individual, and feeling as if one is watching himself or herself do something from a distance (Wright & Loftus, 1999). Dissociation is mostly conceptualized as a continuum ranging from non-pathological dissociative states commonly experienced in daily life (e.g., daydreaming) to pathological types of dissociation manifested in clinical dissociative disorders (Waller, Putnam, & Carlson, 1996). The Dissociative Experiences Scale developed by Bernstein and Putnam (1986) is a widely-accepted measure of the frequency of dissociative experiences in daily life (Van IJzendoorn & Schuengel, 1996). Given that dissociation reflects a form of detachment from the present conscious experience, it can be argued that dissociation and mindfulness are inversely related and that those individuals who tend to have frequent dissociative experiences should demonstrate lower levels of mindfulness in their daily life. Therefore, it was predicted that frequency of dissociative experiences would be negatively associated with trait mindfulness and would be positively associated with mind wandering tendency.

Following are the primary hypotheses, along with their respective research questions, that were tested in Experiment 1.

1. Does a brief mindfulness intervention regulate the occurrence of mind wandering and mitigate the disruptive effect of mind wandering on comprehension?
 - Hypothesis 1: When compared to the control groups, the mindfulness group will have higher rates of self-caught TUTs.
 - Hypothesis 2: When compared to the control groups, the mindfulness group will have fewer probe-caught TUTs.
 - Hypothesis 3: When compared to the control groups, the mindfulness group will retrospectively report having more TUTs.
 - Hypothesis 4: When compared to the control groups, the mindfulness group will have better comprehension scores.
2. Does mind wandering mediate the relationship between WMC and comprehension?
 - Hypothesis 5: WMC will have an indirect effect on comprehension through mind wandering.

Method

Experiment 1 employed a one-factor between-subjects design with three conditions: no-treatment control, listening, and mindfulness meditation. Participants were randomly assigned to one of the three conditions. The primary dependent variables were self-caught TUTs, probe-caught TUTs, retrospective report of TUTs, and lecture comprehension.

Participants

Participants were recruited from the Department of Psychology's undergraduate participant pool. A total of 183 undergraduate students participated in the experiment in exchange for course credit. The data for six participants were removed as a result of a check

for outliers, following the procedure described by Field (2013). This resulted in a sample size of 177 undergraduate students (95 females) with a mean age of 19.8 years old. There were 59 participants in each of the three conditions.

Materials

Demographics questionnaire. Participants completed a questionnaire containing several demographic questions. The questionnaire also included questions regarding participants' experience with meditation (e.g., whether or not they have prior experience with any form of meditation). Only 12 participants (6.8%) indicated having prior experience with meditation. A preliminary analysis revealed that there were no statistically significant differences in any of the dependent variables between those participants who indicated having prior experience with meditation and those who had no experience with meditation.

Mind Wandering Questionnaire. Participants completed the Mind Wandering Questionnaire (MWQ) developed by Mrazek, Phillips et al. (2013). The MWQ is a 5-item, brief questionnaire used as a measure of general propensity for mind wandering, or mind wandering tendency in daily life. Greater scores on the MWQ indicated greater mind wandering tendency. The MWQ is available in Appendix A.

Media Multitasking Index. The Media Multitasking Index (MMI, Ophir et al., 2009) includes questions regarding various media multitasking behaviors. Due to time constraints, a modified version of the MMI including the types of media most relevant to college students was administered in Experiment 1. For each type of these media (i.e., watching TV or videos, surfing the Web, using social media, playing video games, reading, doing homework, and listening to lectures or presentations), participants indicated how often they engaged in that

medium simultaneously while engaging in each of the other type of media, using a four-point scale. Based on participants' frequency rating for each type of media, an MMI was computed for each participant. Greater MMI scores indicated increased frequency of media multitasking. The MMI is available in Appendix B.

Mindful Attention Awareness Scale. Mindful Attention Awareness Scale (MAAS, Brown & Ryan, 2003) is a 15-item measure of dispositional mindfulness, focusing on trait-like aspects of mindfulness. The responses to the scale items were reverse-coded and an MAAS score was calculated for each participant by averaging the responses to the items in the scale. Greater scores on the MAAS indicated greater trait mindfulness. The MASS is available in Appendix C.

Dissociative Experiences Scale. Dissociate Experiences Scale (DES, Bernstein & Putnam, 1986) is a 28-item scale that measures the frequency of dissociative experiences individuals may have in daily life. Experiment 1 used a 20-item modified version of the DES due to the sensitive nature of the remaining eight items concerned with traumatic experiences. A DES score was computed for each participant by averaging the responses to the items in the scale. Greater scores on the DES indicated greater frequency of dissociative experiences. The modified DES is available in Appendix D.

WMC task. Participants performed a short WMC task, specifically the OSPAN. The OSPAN task is widely used in working memory research (Foster et al., 2015; Oswald, McAbee, Redick, & Hambrick, 2015) and requires participants to solve a set of basic math operations while trying to remember a series of unrelated letters. The E-Prime experiment file for the OSPAN task used by Foster et al. (2015) was obtained from the Attention and

Working Memory Lab at Georgia Institute of Technology. The task was automated and participants used the computer mouse to advance to next steps in the test. Participants first saw the math operation (e.g., $(1*2) + 1 = ?$). After clicking the mouse to indicate that they have solved the problem, they were asked to indicate whether the answer shown on the screen was true or false. Afterwards they saw a letter on the screen to be recalled at the end of a sequence (e.g., "L"). Participants completed one block of the OPSAN task consisting of 25 math problems and 25 letters. WMC was indexed by the OSPAN total score, which indicated the total number of letters recalled in the correct position (Oswald et al., 2015). A greater OSPAN score indicated a greater WMC. As commonly done in WMC studies, the OSPAN score for participants who scored below the 85% accuracy threshold on the math task was excluded. This resulted in the elimination of the OSPAN score for 17 participants.

Audio recordings. Participants in the mindfulness group listened to and practiced a brief guided mindfulness meditation recording by Jon Kabat-Zinn (Kabat-Zinn, 2014, track 1), whose recordings have been previously used in other studies to cultivate a mindfulness state (e.g., Hoogland, 2011). This recording is designed to prompt the listener to pay attention to his or her breathing and to try to experience the present moment without judgment. This guided mindfulness meditation recording was 10 minutes long. Those assigned to the listening group listened to an audiobook for the same amount of time as the mindfulness training. Specifically, participants in the listening group listened to a portion of the audiobook of JRR Tolkien's *The Hobbit*, which has also been used in previous studies (Hoogland, 2011; Zeidan et al., 2010). The portion of the audiobook used in Experiment 1 corresponded to the first chapter of the book and it was 10 minutes long. Participants in the

no-treatment control group listened to no audio recording, but directly proceeded to the lecture video, instead.

Toronto Mindfulness Scale. Toronto Mindfulness Scale (TMS, Lau et al., 2006) is a 13-item, self-reported measure of state mindfulness. The TMS was developed to measure the state-like experience of mindfulness following a mindfulness meditation practice, and therefore, it focuses on state-like aspects of mindfulness, rather than attempting to measure mindfulness as a trait. Participants in the mindfulness and listening groups completed the TMS immediately after the audio recording, whereas the control group completed it after the completion of the WMC task and right before they began watching the lecture video. Greater TMS scores indicated greater levels of induced mindfulness state. The TMS was used as a manipulation check to assess whether the mindfulness manipulation influenced self-reported levels of state mindfulness. The TMS is available in Appendix E.

Lecture video. Given the diversity of the students in the undergraduate participant pool, the lecture video chosen for this study needed to be fairly relevant to many of the students in the participant pool, but at the same time it also needed to be peculiar enough so that students would not have a strong background in the lecture material, eliminating the chances that they would score high on the comprehension test regardless of the manipulation. Hence, the lecture video chosen for this study was a 22-minute introductory lecture on homeostasis taken from an introductory physiology course on Coursera (Duke University, 2016), a leading MOOC provider website. The participants were informed that they would watch a lecture video and that they would take a comprehension test on the lecture material at the end.

Dundee Stress State Questionnaire. The Dundee Stress State Questionnaire (DSSQ, Matthews et al., 1999) has been extensively used as a retrospective measure of mind wandering (Smallwood et al., 2004; Smallwood, O'Connor, & Heim, 2005). In the DSSQ participants indicate the extent to which they had various thoughts while completing a task. Immediately following the lecture video, participants completed the DSSQ to report how often they engaged in the presented thoughts. The average score on the DSSQ was used as a retrospective measure of TUTs during the lecture video. Greater scores indicated greater frequency of having TUTs during the lecture video. The DSSQ is available in Appendix F.

Post-video questionnaire. Following the retrospective reports of TUTs, participants completed a post-video questionnaire containing questions regarding their interest in the lecture video content, their motivation to learn from the lecture video, and their background knowledge about the lecture material. The post-video questionnaire is available in Appendix G.

Comprehension test. The comprehension test included 14 multiple choice questions assessing the comprehension of the lecture video material. The questions were developed based on the lecture video material, considering the objectives of the lecture video presented at the beginning, and were piloted with undergraduate research assistants in the lab to ensure the validity of the comprehension test. The comprehension score for each participant was the proportion of questions answered correctly on the test. No question in the comprehension test had a 100% accuracy rate and thus all questions were included in the calculation of the comprehension score. Greater comprehension scores indicated better comprehension of the lecture material. The comprehension test is available in Appendix H.

Mind wandering probes. Schooler et al. (2011) proposed using a combination of probe-caught and self-caught methods of thought sampling when one is interested in the meta-awareness of mind wandering. In the probe-caught method, participants are intermittently probed and asked whether or not they have been mind wandering as well as the contents of their TUTs (Smallwood & Schooler, 2006). In the self-caught method, participants are asked to press a key when they notice they have been mind wandering (Smallwood & Schooler, 2006). The latter serves as a means of determining the extent to which participants are aware of their mind wandering episodes, while the former provides an estimate of the frequency of mind wandering episodes without awareness (Schooler et al., 2011; Smallwood & Schooler, 2015). Therefore, in this study, both methods were used (see Appendix I for thought sampling instructions). Specifically, in the probe-caught method, participants were quasi-randomly probed five times throughout the video. The probes were presented approximately 5, 8, 12, 17, and 21 minutes into the lecture video. In the self-caught method, participants were instructed to press the space bar whenever they noticed they had been mind wandering during the lecture video. Participants practiced both methods prior to watching the lecture video. The probe-caught TUTs variable was calculated as the proportion of probes to which participants indicated mind wandering. For instance, a participant who indicated mind wandering to four out of five probes would have a score of .80 for their probe-caught TUTs variable. The self-caught TUTs variable was calculated as the sum of key presses (space bar) throughout the lecture video. Figure 2 illustrates this thought sampling procedure.

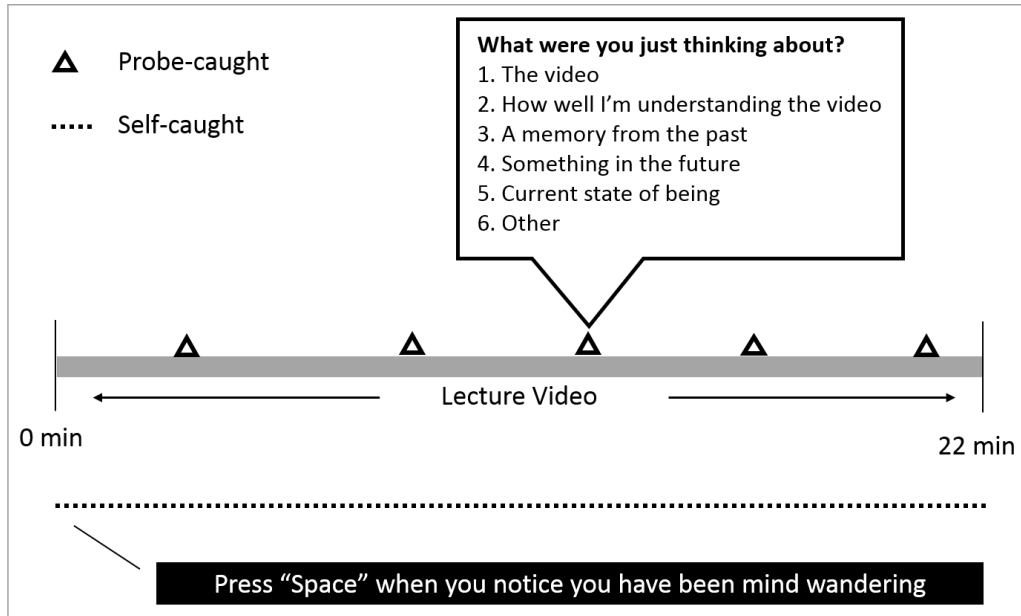

Figure 2. The thought sampling paradigm used in Experiment 1.

Procedure

Upon arrival to the lab, participants were briefed about the study and they signed the informed consent form. Then, they completed an online Qualtrics survey (Qualtrics, Provo, UT; <http://www.qualtrics.com>) that contained the demographics questionnaire, the MWQ, the MAAS, the DES, and the MMI. Participants then completed the WMC task. Next, participants in the mindfulness group listened to and practiced the 10-minute guided mindfulness meditation, whereas the listening group listened to the audiobook for 10 minutes. The no-treatment control group listened to no audio recording, but directly proceeded to the lecture video.

After the audio phase, if any, participants completed the TMS to report their level of state mindfulness. Then they were informed about the concept of mind wandering and the thought sampling procedure to be used to capture their mind wandering episodes was described. Having practiced both the probe-caught and self-caught methods and having

been told that there would be a test at the end, participants began watching the video. Throughout the video, participants were intermittently probed and asked to indicate whether they had been mind wandering. The probes appeared approximately 5, 8, 12, 17, and 21 minutes into the lecture video. Also, participants were asked to press the space key bar anytime they noticed they had been mind wandering throughout the lecture video. At the end of the lecture video, participants completed the retrospective measure of mind wandering, followed by the post-video questionnaire assessing their interest in the lecture video content, motivation to learn from the lecture video, and prior knowledge about the lecture material. Lastly, they took the comprehension test assessing the comprehension of the material covered in the lecture. After completion of the test, participants were debriefed about the purpose of the study.

The E-Prime 2.0 software (Psychology Software Tools, Pittsburgh, PA) was used to present all stimuli and tasks, except for the initial questionnaires. All materials and procedures used in the current dissertation were reviewed and approved by the Iowa State University Institutional Review Board (IRB). The first page of the IRB approval is available in Appendix M.

Results

Results from the current experiment are presented in two sections. In the first section, results concerning the effects of experimental manipulations are presented, together with the results of hypothesis testing. In the second section, descriptive statistics for individual differences measures are summarized, along with the correlations among these measures and comparisons of these measures across the three conditions as well as the

results of various moderation and mediation analyses, exploratory analysis, and some structural equation modeling.

Data analysis was conducted in SPSS and the PROCESS macro (Hayes, 2013) was used for bootstrapped mediation and moderation analyses. Also, MPLUS was used for structural equation modeling. Lastly, Bayes factors were computed using JASP (JASP Team, 2016). For all statistical significance analyses, an alpha level of .05 was used.

Bayes factors, or BFs, represent the ratio of the likelihood of the data fitting under the null hypothesis to the likelihood of the data fitting under the alternative hypothesis (Jarosz & Wiley, 2014). As an alternative to null hypothesis significance testing, Bayesian hypothesis testing is a comparative approach, in which the fit of the data under the null hypothesis is compared to the fit of the data under the alternative hypothesis (Wagenmakers, 2007). Therefore, BFs are used to judge the weight of the evidence obtained from the data in favor of either the null hypothesis (BF_{01}) or the alternative hypothesis ($BF_{10} = 1 / BF_{01}$). For instance, a BF of 5 in favor of the null hypothesis, denoted as $BF_{01} = 5$, indicates that the data are five times more likely to fit under the null hypothesis than under the alternative hypothesis.

Effects of the experimental manipulation

Descriptive statistics for the dependent variables are presented in Table 1 and are visualized in Figure 3. It is important to note that the mean values for all dependent variables were close to each other and that most of the confidence intervals overlapped.

Table 1. Descriptive statistics for dependent variables

	Group			
	No-treatment (N = 59)	Listening (N = 59)	Mindfulness (N = 59)	Total (N = 177)
Self-caught TUTs	14.19 (11.37) [12.22, 17.78]	17.41 (13.54) [15.06, 21.88]	17.64 (14.15) [13.74, 20.91]	16.41 (13.10) [14.80, 18.69]
Probe-caught TUTs	.61 (.30) [.52, .68]	.63 (.26) [.55, .70]	.57 (.32) [.45, .63]	.60 (.29) [.54, .64]
Retrospective TUTs	2.23 (.61) [2.07, 2.38]	2.38 (.55) [2.21, 2.47]	2.35 (.62) [2.16, 2.43]	2.32 (.59) [2.20, 2.37]
Comprehension	.55 (.17) [.51, .61]	.59 (.16) [.56, .64]	.58 (.21) [.53, .64]	.57 (.18) [.56, .61]
State mindfulness	1.83 (.81) [1.57, 1.99]	1.96 (.65) [1.77, 2.11]	1.89 (.75) [1.68, 2.09]	1.89 (.74) [1.75, 1.98]

Means and standard deviations (in parentheses) are reported for dependent variables. Bias-corrected and accelerated (BCa) bootstrapped confidence intervals are reported in brackets. Self-caught TUT refers to the average frequency of self-caught mind wandering. Probe-caught TUT refers to the average proportion of probes to which participants indicated mind wandering. Retrospective TUT refers to the average score on the retrospective measure of mind wandering (max = 5). Comprehension refers to the average proportion of correct answers in the comprehension test. State mindfulness refers to the average score on the Toronto Mindfulness Scale (max = 4).

Correlations among these variables are presented in Table 2 and correlations among all study variables are presented in APPENDIX J. As shown in Table 2, all three measures of mind wandering (self-caught TUTs, probe-caught TUTs, and retrospective reports of TUTs) were moderately associated with each other. The average proportion of correct answers in the comprehension test was negatively correlated with the proportion of probe-caught TUTs, $r(175) = -.34, p < .01$, and with the retrospective self-reported TUTs, $r(175) = -.28, p < .01$.

Table 2. Correlations among the dependent variables

Measure	1	2	3	4
1. Self-caught TUTs	-	.		
2. Probe-caught TUTs	.426**			
3. Retrospective TUTs	.395**	.475**		
4. Comprehension	-.106	-.341**	-.227**	
5. State mindfulness	-.007	.029	.125	.051

** $p < .01$.

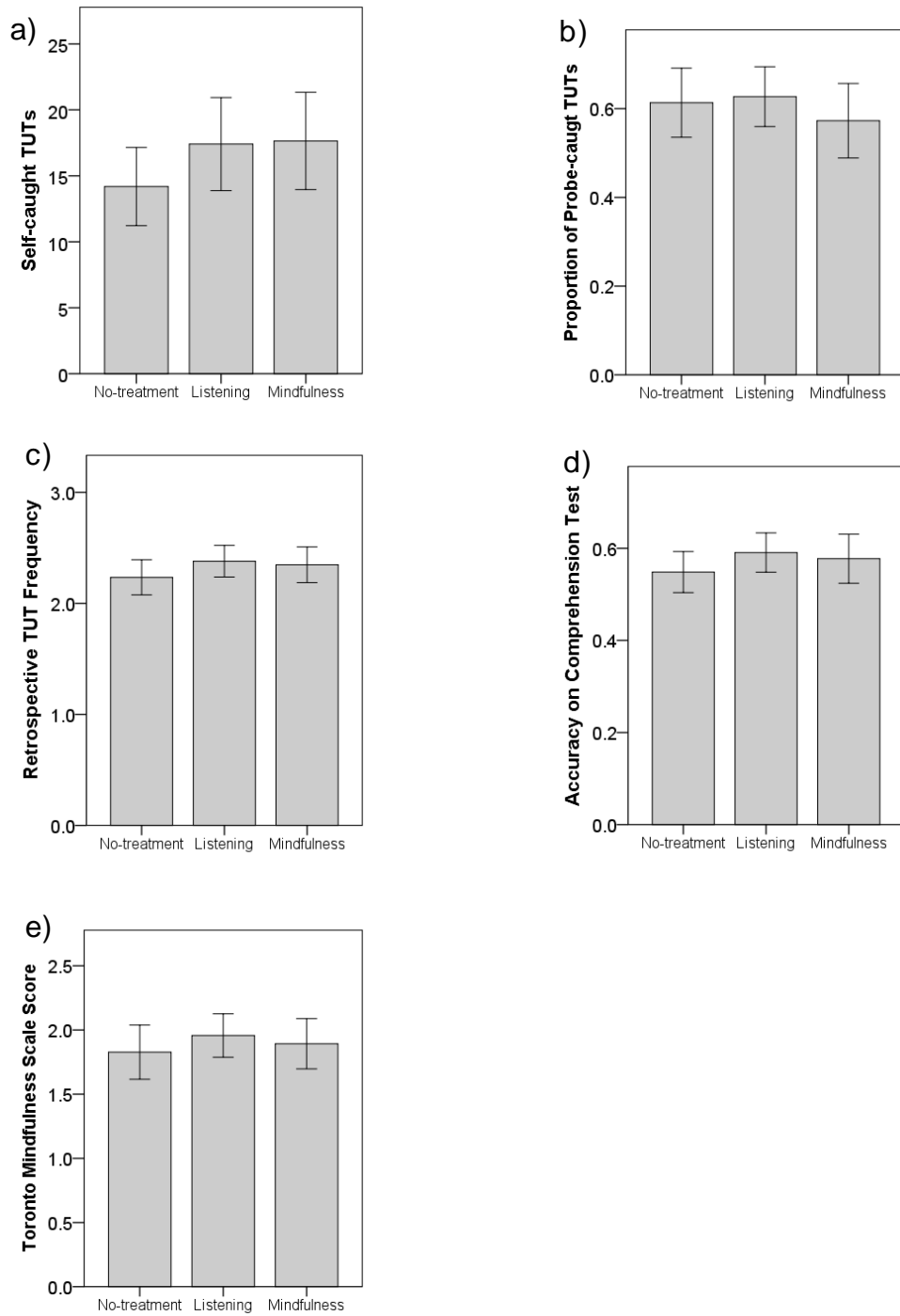

Figure 3. Bar graphs showing the results for each dependent measure as a function of condition: (a) the average number of self-caught TUTs, (b) the average proportion of probe-caught TUTs, (c) the average score on the retrospective report of TUTs, (d) the average proportion of the correct responses on the comprehension test, and (e) the average score on the Toronto Mindfulness Scale. Error bars represent 95% confidence intervals.

To test the hypotheses, a univariate analysis of variance (ANOVA) was conducted on each dependent measure with the between-subjects factor condition (i.e., no-treatment, listening, and mindfulness). The results from separate ANOVAs for each dependent variable are presented in Table 3. Levene's test of Homogeneity of Variances indicated equal variances among the three groups for all ANOVAs.

Table 3. ANOVA results for dependent variables

Source	<i>df</i>	<i>MS</i>	<i>F</i>	<i>p</i>	η^2	ω^2	<i>BF</i> ₀₁
Self-caught TUT							
Between groups	2	220.09	1.287	.279	.015	.003	5.73
Within groups	174	170.95					
Probe-caught TUT							
Between groups	2	.05	.542	.583	.006	.000	10.93
Within groups	174	.09					
Retrospective TUT							
Between groups	2	.34	.984	.376	.011	.000	7.45
Within groups	174	.35					
Comprehension							
Between groups	2	.03	.847	.430	.010	.000	8.39
Within groups	174	.03					
State mindfulness							
Between groups	2	.25	.451	.638	.005	.000	11.82
Within groups	174	.55					

One-way ANOVA results are presented for each dependent variable. *BF*₀₁ represents the Bayes factor in favor of the null hypothesis.

Hypothesis 1 was that when compared to the control groups, the mindfulness group would have higher rates of self-caught TUTs. The results of the ANOVA revealed no significant effect of experimental condition on the frequency of self-caught TUTs, $F(2, 174) = 1.287$, $MSE = 170.95$, $p = .279$, $\omega^2 = .003$, $BF_{01} = 5.73$. Planned contrasts revealed no significant differences between the mindfulness training group and the two control groups in the frequency of self-caught TUTs, $t(174) = .886$, $p = .189$ (one-tailed), $r = .067$. The

pairwise comparison of the no-treatment group with the listening control group was non-significant, $t(174) = 1.338$, $p = .92$ (one-tailed), $r = .101$. These results suggest that, contrary to Hypothesis 1, a 10-minute mindfulness meditation training did not increase meta-awareness of mind wandering.

Hypothesis 2 was that when compared to the control groups, the mindfulness group would have fewer probe-caught TUTs. The results of the ANOVA revealed no significant differences among the three conditions in the proportion of probe-caught TUTs, $F(2, 174) = .984$, $MSE = .09$, $p = .376$, $\omega^2 = .000$, $BF_{01} = 10.93$. Planned contrasts revealed no significant differences between the mindfulness training group and the two control groups in the proportion of probe-caught TUTs, $t(174) = -1.01$, $p = .157$ (one-tailed), $r = .076$. The pairwise comparison of the no-treatment group with the listening control group was non-significant, $t(174) = .250$, $p = .402$ (one-tailed), $r = .019$. These results suggest that, contrary to Hypothesis 2, a 10-minute mindfulness meditation training did not reduce zoning out during lectures.

Hypothesis 3 was that when compared to the control groups, the mindfulness group would retrospectively report having more TUTs. The results of the ANOVA revealed no significant differences among the three conditions for the retrospective report of TUTs, $F(2, 174) = .984$, $MSE = .35$, $p = .376$, $\omega^2 = .000$, $BF_{01} = 7.45$. Planned contrasts revealed no significant differences between the mindfulness training group and the two control groups in the retrospective report of TUTs, $t(174) = .433$, $p = .333$ (one-tailed), $r = .033$. The pairwise comparison of the no-treatment group with the listening control group was non-significant, $t(174) = 1.335$, $p = .92$ (one-tailed), $r = .101$. These results suggest that, contrary to

Hypothesis 3, a 10-minute mindfulness meditation training did not lead to an increased retrospective recognition of mind wandering.

Hypothesis 4 was that when compared to the control groups, the mindfulness group would have better comprehension scores. The results of the ANOVA revealed no significant differences among the three conditions in the proportion of correct answers in the comprehension test, $F(2, 174) = .847$, $MSE = .03$, $p = .430$, $\omega^2 = .000$, $BF_{01} = 8.39$. Planned contrasts revealed no significant differences between the mindfulness training group and the two control groups in the proportion of correct answers in the comprehension test, $t(174) = .273$, $p = .393$ (one-tailed), $r = .021$. The pairwise comparison of the no-treatment group with the listening control group was non-significant, $t(174) = 1.273$, $p = .103$ (one-tailed), $r = .096$. These results suggest that, contrary to Hypothesis 4, a 10-minute mindfulness meditation training did not increase the retention of lecture video material.

Lastly, the results of the ANOVA revealed no significant differences among the three conditions in state mindfulness based on the average scores on the TMS, $F(2, 174) = .451$, $MSE = .55$, $p = .638$, $\omega^2 = .000$, $BF_{01} = 11.82$. Planned contrasts revealed no significant differences between the mindfulness training group and the two control groups in the average scores on the TMS, $t(174) = .007$, $p = .497$ (one-tailed), $r = .001$. The pairwise comparison of the no-treatment group with the listening control group was also non-significant, $t(174) = .950$, $p = .177$ (one-tailed), $r = .072$. These results suggest that a 10-minute mindfulness meditation intervention was not robust enough to induce a mindfulness state.

Overall there was no evidence that the brief mindfulness meditation intervention had any effect on any of the dependent variables. Given that the three conditions did not differ in any of the dependent variables, the rest of the analyses were conducted on the entire dataset from all participants. Furthermore, a regression analysis predicting lecture comprehension from the three measures of mind wandering used in Experiment 1; that is, self-caught TUTs, probe-caught TUTs, and retrospective self-report of TUTs, revealed that the probe-caught TUTs variable ($\beta = -.32, t = -3.83, p < .001$) was the only significant predictor of lecture comprehension, $F(3, 173) = 8.30, MSE = .03, p < .001, R^2 = .126, R^2_{\text{adjusted}} = .111$. Accordingly, following the data analyses procedures from previous studies (e.g., McVay & Kane, 2012; Mrazek et al., 2012, Mrazek, Franklin et al., 2013), the probe-caught TUT measure, which is the average proportion of probes to which participants indicated mind wandering, is used as the measure of the propensity for mind wandering during the lecture video in the following analyses.

Individual differences

Table 4 summarizes the descriptive statistics for the five individual differences measures employed in Experiment 1 across the three conditions. As can be seen from the table, the mean values of each measure do not differ greatly across the three conditions. To check whether the participants in the three conditions differed in any of the individual differences measures, separate one-way ANOVA tests were conducted for each measure. One-way ANOVA tests revealed no statistically significant differences among the three conditions in working memory capacity as measured by OSPAN, $F(2, 157) = .98, MSE = .69, p = .378, BF_{01} = 6.93$, mind wandering tendency, $F(2, 173) = .35, MSE = .69, p = .702, BF_{01} =$

12.79, trait mindfulness or dispositional mindfulness as measured by MAAS, $F(2, 173) = .459$, $MSE = .55$ $p = .633$, $BF_{01} = 11.68$, frequency of dissociative experiences, $F(2, 173) = .546$, $MSE = 2.07$ $p = .480$, $BF_{01} = 10.83$, and media multitasking frequency, $F(2, 173) = .169$, $MSE = .59$ $p = .845$, $BF_{01} = 15.01$. These results indicate that the three groups were homogenous in terms of working memory capacity, mind wandering tendency, dispositional mindfulness, dissociative experiences tendency, and media multitasking frequency. The mean values were comparable to previous studies for WMC (Foster et al., 2014), MWQ (Mrazek, Phillips et al., 2013), MAAS (Mrazek, Phillips et al., 2013), DES (Van IJzendoorn et al., 1996), and MMI (Ralph et al., 2014).

Table 4. Descriptive statistics for individual differences measures across conditions

	Range	Group			Total
		No-treatment	Listening	Mindfulness	
Working memory capacity	0-25	17.13 (5.49) $N = 53$	16.79 (5.35) $N = 53$	18.17 (5.03) $N = 54$	17.37 (5.30) $N = 160$
Mind wandering tendency	1-6	3.82 (.89) $N = 59$	3.93 (.81) $N = 58$	3.93 (.78) $N = 59$	3.89 (.83) $N = 176$
Trait mindfulness	1-6	3.95 (.66) $N = 59$	3.92 (.76) $N = 58$	3.83 (.79) $N = 59$	3.90 (.74) $N = 176$
Dissociative experiences	1-10	2.51 (1.41) $N = 59$	2.65 (1.47) $N = 58$	2.79 (1.43) $N = 59$	2.65 (1.43) $N = 176$
Media multitasking frequency	1-6	2.59 (.70) $N = 59$	2.61 (.85) $N = 58$	2.67 (.76) $N = 59$	2.62 (.77) $N = 176$

Means and standard deviations (in parentheses) are reported for individual differences measures. Working memory capacity, as measured using the Automated Operation Span (OSPAN) task, indicates the average OSPAN total score. Mind wandering tendency indicates the average score on the MWQ. Trait mindfulness indicates the average score on the MAAS. Dissociative experiences indicates the average score on the DES. Media multitasking frequency indicates the average score on the modified version of MMI.

Table 5 shows the correlations among the individual differences measures across all participants. Because the three experimental groups did not differ in any of the dependent variables, the correlation analysis was conducted on the data from all participants.

Table 5. Correlations among individual differences measures across all participants

Measure	1	2	3	4	5
1. Working memory capacity	159				
2. Mind wandering tendency	.025	176			
3. Trait mindfulness	-.059	-.727**	176		
4. Dissociative experiences	.015	.263**	-.424**	176	
5. Media multitasking frequency	-.100	.361**	-.359**	.217**	176

Values on the diagonal indicate the number of participants whose data were included in the analysis of each individual differences measure. * $p < .05$. ** $p < .01$.

As seen in Table 5, in line with previous research (Mrazek et al., 2012), trait mindfulness and mind wandering tendency were negatively correlated, $r(174) = -.73, p < .01$, suggesting that individuals who reported higher levels of trait mindfulness reported less mind wandering tendency. Also, self-reported trait mindfulness was negatively associated with frequency of dissociative experiences, $r(174) = -.42, p < .01$, suggesting that individuals who reported higher levels of trait mindfulness were less likely to have dissociative experiences. As expected, the frequency of dissociative experiences was positively associated with mind wandering tendency, $r(174) = .26, p < .01$, indicating that those who tended to have more dissociative experiences were more likely to mind wander in daily life. In relation to media multitasking behaviors, increased levels of media multitasking frequency were positively associated with the frequency of dissociative experiences, $r(174) = .22, p < .01$, and mind wandering tendency, $r(174) = .36, p < .01$, and they were negatively associated with trait mindfulness, $r(174) = -.36, p < .01$. Of note, working memory capacity was not correlated with any of the other four individual differences measures.

The role of TUTs in the relationship between WMC and comprehension. Based on Hypothesis 5, it was expected that mind wandering would mediate the relationship between working memory capacity and lecture comprehension. Specifically, WMC was hypothesized to have an indirect effect on comprehension scores through mind wandering, with high WMC individuals having fewer mind wandering episodes, which in turn would lead to better performance on the comprehension test. To test this hypothesis, a bootstrapped mediation analysis was conducted using the PROCESS macro for SPSS (Hayes, 2013). The results of the mediation analysis for all participants are presented in Figure 4. As can be seen in Figure 4, working memory capacity did not predict mind wandering, nor did it have any direct or indirect effects on lecture comprehension. Mind wandering, however, did predict performance decrements on the comprehension test, $b = -.19, p = .0001, 95\% \text{ CI } [-.278, -.096], F(2, 157) = 8.26, \text{MSE} = .029, p = .0004, R^2 = .10$, indicating that increased mind wandering without awareness, or zoning out, during the lecture video led to poorer comprehension of the lecture material.

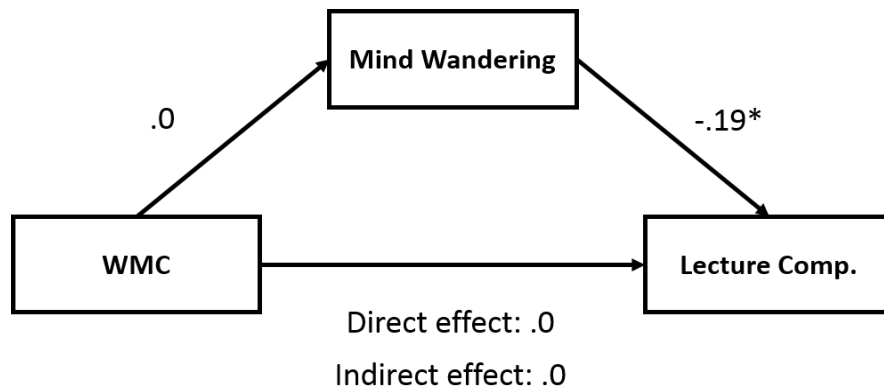

Figure 4. Regression coefficients for the relationship between working memory capacity and lecture comprehension as mediated by mind wandering. Working memory capacity is indexed by quadratic OSPAN score. Mind wandering indicates the proportion of probe-caught TUTs. Lecture comprehension indicates the proportion of correct answers on the comprehension test. See Appendix K for additional related analyses.

Individual differences in the propensity for mind wandering. To explore what individual differences may predict the propensity for mind wandering during lecture videos, a multiple regression analysis was conducted, regressing the proportion of probe-caught mind wandering on the five individual differences measures: working memory capacity, media multitasking index, dissociative experiences tendency, mind wandering tendency, and trait mindfulness. The results are presented in Table 6.

Table 6. Exploratory regression analysis predicting mind wandering

Variable	<i>B</i>	<i>SE B</i>	β	<i>t</i>
Constant	-.619	.346		-1.79
Working Memory Capacity	.000	.000	-.006	-.07
Media Multitasking Index	-.013	.034	-.033	-.40
Dissociative Experiences Tendency	.026	.017	.124	1.46
Mind Wandering Tendency	.169	.040	.459**	4.26
Trait Mindfulness	.133	.048	.320**	2.76
<i>R</i> ²		.115		
<i>R</i> ² Adjusted		.09		
<i>F</i>		3.96**		

** $p < .01$.

As can be seen in Table 6, the five-predictor model accounted for 12% of the variance in the average proportion of probe-caught mind wandering. $F(5, 153) = 3.96$, $MSE = .08$, $p = .002$, $R^2 = .12$, $R^2_{\text{adjusted}} = .09$. Of all the five predictors, only mind wandering tendency ($beta = .46$, $t = 4.26$, $p < .01$) and trait mindfulness ($beta = .32$, $t = 2.76$, $p < .01$) significantly contributed to the model. As expected, individuals who reported a greater tendency to mind wander in daily life were caught mind wandering more frequently during the experiment than those who reported a relatively lesser proclivity for mind wandering in daily life. Interestingly, however, individuals who reported high dispositional mindfulness were

caught mind wandering during the experiment more frequently than those reporting relatively lower levels of dispositional mindfulness.

A close scrutiny of the collinearity statistics of the predictor variables revealed that the tolerance values for MWQ and MAAS were greater than .20 (.50 and .43 respectively) and that the VIF values were less than 5 (2.01 and 2.32 respectively), indicating the nonexistence of a multicollinearity problem (Field, 2013). Interestingly, trait mindfulness and the propensity for mind wandering were not correlated, but the multiple regression analysis showed that trait mindfulness was a significant predictor of the propensity for mind wandering. This, coupled with the fact that trait mindfulness and mind wandering tendency were moderately correlated, $r(174) = -.73, p < .01$, suggests that the MAAS predictor (trait mindfulness) may be a suppressor variable in the prediction model (Smith, Ager, & Williams, 1992; Thompson & Levine, 1997). Suppressor variables are said to increase the variance explained by another predictor – the MWQ predictor in this case - by removing the error variance in the predictor variable attributable to measurement artifacts and thus they increase the predictive ability of the other predictor(s) as a potential explanation for the outcome variable. To examine the potential of the MAAS variable as a suppressor variable, the same regression analysis was run by respectively removing the MAAS and MWQ variables from the model. The exclusion of the MAAS predictor from the model led to a reduction in the variance accounted for by the model, $F(4,154) = 3.0, MSE = .082, p < .05, R^2 = .072$, and in the beta-weight for the MWQ predictor ($beta = .269, p < .01$). The exclusion of the MWQ predictor from the model led to a nonsignificant regression model with no

significant predictors, $F(4,154) = .406$, $MSE = .088$, $p = .804$, $R^2 = .072$. Taken together, these results indicate that the MAAS predictor does have a suppression effect.

Individual differences in the effect of TUTs on comprehension. To examine the moderation effects of individual differences measures on the relationship between TUTs during the lecture video and lecture comprehension, separate moderation analyses were run using the PROCESS macro for SPSS with 1000 bias-corrected bootstrapped samples. The predictors were centered (Field, 2013). Results are presented in Table 7.

In relation to the moderating role of working memory capacity (WMC) in the relationship between TUTs during the lecture video and lecture comprehension, the moderation analysis revealed that WMC, as indexed by OSPAN, did not moderate the relationship between mind wandering during the lecture video (proportion of probe-caught TUTs) and lecture comprehension. The OSPAN by TUT interaction was non-significant, $b = .000$, $[-.001, .001]$, $p > .05$. Overall, the moderation model including WMC and TUTs predicted 9.5% variance in the performance on the lecture comprehension test, $F(3, 156) = 5.49$, $MSE = .029$, $p < .01$.

Similarly, there was no moderation effect of mind wandering tendency, $b = -.012$, $[-.110, .087]$, $p > .05$, trait mindfulness, $b = .056$, $[-.053, .165]$, $p > .05$, the frequency of dissociative experiences, $b = -.038$, $[-.095, .019]$, $p > .05$, and media multitasking frequency, $b = -.072$, $[-.178, .035]$, $p > .05$, on the relationship between mind wandering during the lecture video and lecture comprehension. The variance in the performance on the lecture comprehension test explained by the moderation model was 12.4% for mind wandering tendency, $F(3, 172) = 8.14$, $MSE = .029$, $p < .001$, 13.5% for trait mindfulness, $F(3, 172) = 8.14$,

$MSE = .029, p < .001, 12.6\%$ for the disposition to have dissociative experiences $F(3, 172) = 8.26, MSE = .029, p < .001,$ and 12.7% for media multitasking frequency, $F(3, 172) = 8.33, MSE = .029, p < .001.$ These results suggest that there are no individual differences in the influence of mind wandering on lecture comprehension in terms of working memory capacity, mind wandering tendency, trait mindfulness, frequency of dissociative experiences, and media multitasking frequency.

Table 7. Moderation effects of individual differences measures on the relationship between mind wandering (TUT) and lecture comprehension (COMP)

Predictors	<i>B</i>	<i>SE</i>	BCI ₉₅ for <i>B</i>		<i>t</i>	<i>p</i>
			Lower	Upper		
Constant	.582	.014	.555	.609	42.91	.000
OSPAN	.000	.000	-.000	.000	.28	.784
TUT	-.187	.046	-.279	-.096	-4.04	.000
OSPAN x TUT	.000	.000	-.001	.001	.21	.834
Constant	.573	.013	.547	.599	43.09	.000
MWQ	.020	.016	-.013	.052	1.20	.230
TUT	-.226	.046	-.317	-.136	-4.94	.000
MWQ x TUT	-.012	.050	-.110	.087	-.24	.813
Constant	.576	.013	.548	.599	44.56	.000
MAAS	-.031	.018	-.066	.004	-1.76	.080
TUT	-.219	.044	-.305	-.132	-4.98	.000
MAAS x TUT	.056	.055	-.053	.165	1.01	.312
Constant	.574	.013	.549	.600	44.33	.000
DES	-.003	.009	-.021	.015	-.29	.769
TUT	-.205	.044	-.293	-.118	-4.64	.000
DES x TUT	-.038	.029	-.095	.019	-1.32	.188
Constant	.573	.013	.548	.599	44.45	.000
MMI	.009	.016	-.025	.041	.511	.610
TUT	-.217	.044	-.304	-.130	-4.91	.000
MMI x TUT	-.072	.054	-.178	.035	-1.32	.188

The outcome variable is the comprehension score for all models and represents the average proportion of correct answers in the comprehension test. OSPAN represents working memory capacity, as indexed by the average OSPAN total score. MWQ represents mind wandering tendency. MAAS represents trait mindfulness. DES represents the disposition to have dissociative experiences. MMI represents media multitasking frequency. BCI₉₅ refers to bootstrapped (1000) 95% confidence intervals.

Situational factors in the propensity for mind wandering. In relation to the influence of mind wandering on comprehension, previous research has also explored what situational factors may play a role in the propensity for mind wandering and its influence on comprehension, specifically focusing on interest in the material, motivation to learn the material, and background knowledge in the material to be learned (e.g., Unsworth & McMillan, 2013). To examine how interest in the lecture material, motivation to learn from the lecture video, and prior knowledge of the lecture material may play a role in the propensity for mind wandering during the lecture video and in its effects on lecture comprehension, confirmatory factor analysis and structural equation modeling were utilized.

The comprehension test was separated into three parcels based on factor analysis. A one-factor solution was requested for the 14 questions in the comprehension test and the items were rank-ordered from highest to lowest based on the factor matrix so that the average factor loading of each parcel would be roughly equal. Consequently, Questions 1, 3, 4, 9, and 10 were included in the first parcel (Comp1), Questions 5, 7, 8, 13, and 14 in the second parcel (Comp2), and Questions 2, 6, 11, and 12 in the third parcel (Comp3). These three parcels were loaded onto the same factor to form the lecture comprehension factor. Similarly, responses to mind wandering probes were divided into two parcels. The first TUT parcel (TUT1) contained the average of first three probes and the second TUT parcel (TUT2) included the last two probes. A TUT factor was formed by loading these two TUT parcels onto the same factor. Moreover, the two questions for interest, motivation, and prior

knowledge were loaded together onto the same factor to form a separate factor for each of these domain-specific factors.

Having formed the latent factors, the measurement model was tested via confirmatory factor analysis (CFA) in MPLUS to determine if the proposed model fit the data.

Table 8 shows the loadings of the manifest variables on the specified latent variables and

Table 9 shows the correlations among the latent variables.

Table 8. Loadings of manifest variables on latent variables

Factor	Items	Loading	SE
Comprehension	Comp1	.521***	.075
	Comp2	.518***	.075
	Comp3	.673***	.070
TUT	TUT1	.770***	.066
	TUT2	.621***	.066
Interest	INT1	.933***	.026
	INT2	.895***	.028
Background	BG1	.901***	.126
	BG2	.553***	.093
Motivation	MOT1	999	999
	MOT2	999	999

The two motivation items did not load onto the motivation factor.
***. $p < .001$.

Table 9. Correlations among latent variables

	1	2	3	4	5
1. Comprehension	.014				
2. TUT	-.536***	.059			
3. Interest	.575***	-.603***	.756		
4. Background	.428***	-.034	.352***	.903	
5. Motivation	999	999	999	999	-.374

Values on the diagonal indicate the variance for each factor. ***. $p < .001$

As can be seen from Table 8, with the exception of the motivation variables, all variables significantly loaded onto their specified factors. The two motivation items did not load onto the motivation factor and thus the factor could not be identified. A quick scrutiny

of Table 9 reveals that all factors significantly correlated with one another, except for the motivation factor. Results of the CFA showed that the measurement model fit was good ($\chi^2(40) = 46.90, p = .21; CFI = .98; RMSEA = .03$).

Since the motivation factor could not be identified based on the two motivation items, the measurement model was run again without the motivation factor. Table 10 below shows the loadings of the manifest variables on the specified latent variables for the updated measurement model and Table 11 shows the correlations among the latent variables. Results of the CFA showed that the measurement model fit was good ($\chi^2(21) = 24.14, p = .29; CFI = .99; RMSEA = .03$).

Table 10. Loadings of manifest variables on latent variables without the Motivation factor

	Unstandardized		Standardized	
	Loading	SE	Loading	SE
Comprehension				
Comp1	1.000	.000	.529***	.075
Comp2	1.021***	.234	.521***	.076
Comp3	1.449***	.303	.661***	.071
TUT				
TUT1	1.000	.000	.758***	.069
TUT2	1.003***	.181	.631***	.068
Interest				
INT1	1.000	.000	.914***	.031
INT2	1.062***	.082	.915***	.031
Background				
BG1	1.000	.000	.909***	.119
BG2	.589***	.166	.548***	.089

***. $p < .001$

Table 11. Correlations among latent variables without the Motivation factor

	1	2	3	4
1. Comprehension	.015			
2. TUT	-.542***	.057		
3. Interest	.585***	-.603***	.724	
4. Background	.423***	-.032	.358***	.919

Values on the diagonal indicate the variance for each factor. ***. $p < .001$

Based on Table 10, it is observed that each manifest variable significantly loaded onto its respective factor. Examining the correlations among the latent variables, it can be seen that, in line with previous research (McVay & Kane, 2012; Unsworth & McMillan, 2013), comprehension was negatively related to mind wandering, $r(175) = -.54, p < .001$. Also, comprehension was positively associated with topic interest, $r(175) = .56, p < .001$, and prior knowledge of the material, $r(175) = .42, p < .001$, suggesting that those who found the lecture material more interesting and those who reported having more prior knowledge of the lecture material demonstrated better comprehension of the lecture material. Likewise, mind wandering was negatively associated with topic interest, $r(175) = -.60, p < .001$, but not with prior knowledge of the material, $r(175) = -.03, p > .05$, indicating that those individuals who found the lecture material more interesting tended to mind wander less during the lecture video.

Having investigated the fit of the measurement model, structural equation modeling was utilized to examine the interplay among these factors. Specifically, a partial mediation model was investigated to test how interest in the lecture material and prior knowledge of the lecture material affect mind wandering during the lecture video and how these two factors along with mind wandering affect the comprehension of the lecture video, with mind wandering partially mediating the effects of interest and prior knowledge on lecture comprehension. This partial mediation model is illustrated in Figure 5 and model results are presented in Table 12.

Table 12. Path coefficients for the hypothesized mediation model

Outcome	Predictor	β	SE	R ²
Mind Wandering				.403
	Interest	-.679***	.082	
	Prior Knowledge	.211*	.098	
Lecture Comprehension				.487
	Mind Wandering	-.393*	.158	
	Interest	.230	.163	
	Prior Knowledge	.328*	.129	

Model fit: $\chi^2(21) = 24.14, p = .29$; CFI = .99; RMSEA = .03. *. $p < .05$, ** $p < .01$, *** $p < .001$

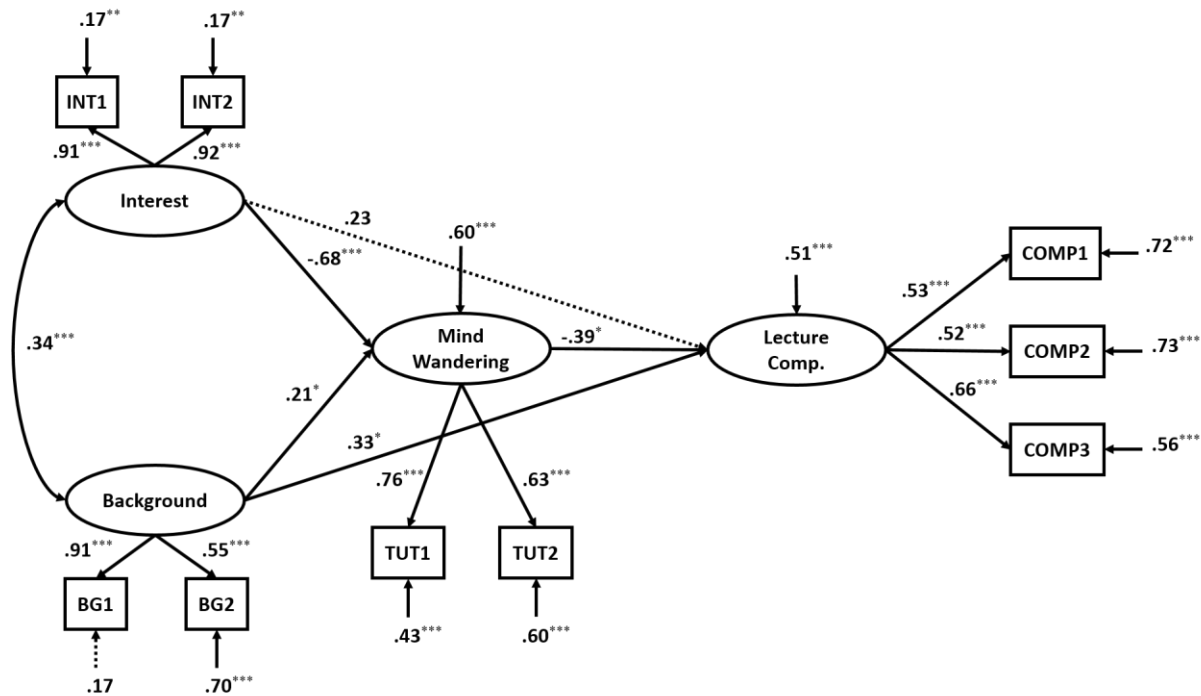

Figure 5. Structural equation model testing the effects of interest and background knowledge on lecture comprehension as mediated by mind wandering (the average proportion of probe-caught mind wandering). Single-headed arrows connecting latent factors (circles) indicate standardized path coefficients, denoting the unique variance explained by the latent factor. Single-headed arrows from latent factors to manifest variables indicate the loadings of those manifest variables on latent factors. Double-headed arrow connecting Interest and Background indicates the correlation between the two factors. Single-headed arrows pointing to manifest variables represent residual variances. Dotted lines are non-significant. Solid lines are significant. *. $p < .05$, ** $p < .01$, *** $p < .001$

As can be seen from Figure 5 and Table 12, interest in and prior knowledge of the lecture material significantly predicted mind wandering while watching the lecture video. Specifically, those who found the lecture material more interesting mind wandered less during the lecture video ($\beta = -.68, p < .001$). Interestingly, those who indicated having more prior knowledge of the lecture material mind wandered more during the lecture video ($\beta = .21, p < .01$). These two factors were significantly associated with each other, $r(175) = .34, p < .001$, and together they accounted for 40.3% of the variance in mind wandering while watching the lecture video, suggesting that interest in and prior knowledge of the lecture material jointly influence the propensity for mind wandering during lecture videos. Furthermore, mind wandering significantly predicted performance on the lecture comprehension test ($\beta = -.39, p < .05$). Also, prior knowledge of the lecture material accounted for significant unique variance in lecture comprehension ($\beta = .33, p < .05$), while interest in the lecture material did not. However, the indirect effect of interest in the lecture material on lecture comprehension through mind wandering was significant (indirect effect = $.27, p < .05$). The indirect effect of prior knowledge of the lecture material was not significant (indirect effect = $.083, p = .104$). Constraining the path from prior knowledge to lecture comprehension to zero yielded a significantly worse fit of the model, $\Delta\chi^2(1) = 7.32, p = .007$, suggesting that prior knowledge of the lecture material accounted for unique variance in lecture comprehension above and beyond that accounted for by its relation with mind wandering. Collectively, interest in and prior knowledge of lecture material and mind wandering accounted for 48.7% of the variance in lecture comprehension while watching the lecture video.

These results indicate that mind wandering during lecture videos is disruptive on the comprehension of the lecture material, which is directly influenced by how much background knowledge an individual has prior to watching the lecture video and is indirectly influenced by how interesting an individual finds the lecture material. Those who have more prior knowledge of the lecture video seem to have the luxury of engaging in task-unrelated thoughts without impeding their comprehension of the lecture video. When an individual is not interested in the lecture material, the individual tends to mind wander more, which results in poorer comprehension of the lecture material.

Discussion

Experiment 1 investigated the influence of a brief mindfulness meditation intervention on mind wandering during an ecologically valid sustained attention task, i.e., learning from a lecture video, and demonstrated that the 10-minute guided mindfulness intervention had no influence on the occurrence of mind wandering during the lecture video, nor on its disruptive effects on lecture comprehension. Based on the meta-awareness hypothesis of mind wandering (Schooler et al., 2011), it was hypothesized that the brief mindfulness intervention would lead to increased meta-awareness of mind wandering (Hypothesis 1) and a reduced likelihood of zoning out (Hypothesis 2). Similarly, it was also expected this brief mindfulness intervention would lead to higher rates of self-reported mind wandering following the lecture video due to increased meta-awareness of the occurrence of mind wandering (Hypothesis 3). Results of the experiment revealed no support for any of these hypotheses: there was no difference across the three conditions in the frequency of self-caught mind wandering episodes, in the proportion of probe-caught mind wandering

episodes, and in the retrospective self-reports of mind wandering. This finding was unexpected on the grounds that a similar brief mindfulness intervention, i.e., an eight-minute mindful breathing practice, has been shown to lead to reductions in indirect performance markers of mind wandering during the SART (Mrazek et al., 2012).

One potential explanation for why the manipulation utilized in Experiment 1 did not produce a recognizable change in mind wandering across groups may be that such brief interventions may work for simple, repetitive laboratory tasks, but may not be robust enough to lead to increased recognition of mind wandering and decreased likelihood of engaging in mind wandering without awareness, or zoning out, during more complex, real-life tasks that require processing, encoding and comprehension of multisensory information (e.g., learning from a lecture video). Another explanation, which is not mutually exclusive from the previous one, may be that a 10-minute mindfulness intervention is not sufficient to induce a mindfulness state that leads to substantial reductions in zoning outs. Repeated and consistent practice may be needed to observe substantial improvements in the capacity to appraise the contents of thought and in the ability to focus attention. The latter explanation is substantiated by the fact that the manipulation check, which involved participants completing the Toronto Mindfulness Scale (TMS), revealed no significant differences across the three groups in state mindfulness levels, suggesting that the mindfulness manipulation might not have influenced state mindfulness levels. This conclusion should be taken with a grain of salt on the grounds that some methodological challenges have been raised regarding the use of self-reported measures, such as TMS, to assess state-like aspects of mindfulness (Baer, 2011; Davidson & Kaszniak, 2015). Baer (2011) and Davison and Kaszniak (2015)

pointed out that mindfulness-naïve participants may not be able to reflect accurately on their current state of being and how mindful they are at the present moment via self-reported measures because of their unfamiliarity with recognizing their engagement in the present moment, which is in fact deemed a skill cultivated through mindfulness practice.

In line with the decoupling hypothesis (Schooler et al., 2011; Smallwood & Schooler, 2006), it was hypothesized that the brief mindfulness meditation practice would lead to better comprehension of the lecture material, as the participants in the mindfulness meditation group were expected to maintain sustained attention on the external task, and thus, they would spend less time in the perceptual decoupling state leading to poor performance on the ongoing task (Hypothesis 4). This hypothesis was not supported either. This null finding related to the fourth hypothesis could be explained by the null findings related to the previous hypotheses, which demonstrated that the brief mindfulness meditation practice produced no substantial changes in mind wandering. The manipulation had no effect on mind wandering, nor did it affect the comprehension of the lecture video.

The second question that guided Experiment 1 was concerned with the mediating role of mind wandering in the relationship between working memory capacity and lecture comprehension. Specifically, based on the executive failure hypothesis (McVay & Kane, 2009, 2010), it was expected that high WMC individuals would have fewer mind wandering episodes and thus demonstrate better comprehension of the lecture video material (Hypothesis 5). While there was no predictive effect of WMC on mind wandering and lecture comprehension, mind wandering during lecture videos predicted performance decrements on the comprehension of lecture material, providing further credence for the well-

documented disruptive effect of mind wandering on task performance (e.g., McVay & Kane, 2012; Mrazek, Franklin et al., 2013; Smallwood, Fishman et al. 2007; Smallwood, McSpadden, Luus, & Schooler, 2008; Reichle et al., 2010; Unsworth & McMillan, 2013; Szpunar et al., 2013). Based on the perceptual decoupling account of mind wandering, those individuals who mind wander more frequently during lectures spend more time in the decoupled state, during which attention is decoupled from the processing of perceptual stimuli and instead is focused on the self-generated TUTs (Schooler et al., 2011; Smallwood & Schooler, 2006). When decoupling occurs, participants fail to build a situation model of the lecture material being covered during TUTs, resulting in poorer comprehension of the lecture material.

It should be noted that Experiment 1 used a shortened version of the OSPAN task. Due to time constraints, participants completed only one block of the OSPAN task. The mean OSPAN total scores were typical and comparable to those reported in previous studies using the same task (e.g., Foster et al., 2014). However, Foster et al. (2014) have recently suggested that use of a shortened test poses a potential threat to the validity of this task in approximating WMC. Therefore, the fact that this study used only one block of the OSPAN task may be the reason for why WMC did not account for any of the variance in the proportion of probe-caught TUTs, leading to null findings regarding the role of WMC in the propensity for mind wandering. These null findings are contrary to previous research on the effect of WMC on the propensity for mind wandering during a demanding task (e.g., McVay & Kane, 2012) and should be cautiously interpreted in light of this limitation. Future research could address this limitation by using the full, three-block version of the OSPAN task, which on average takes approximately 30 minutes to complete, or using a one-block version of the

OSPAN task and a one-block version of the symmetry span task, which also on average takes approximately 30 minutes to complete (Foster et al., 2014). The latter combination of the OSPAN task with the symmetry span task explains an additional 14.9% of the variance in fluid intelligence and is recommended as a better alternative to the three-block version of the OSPAN task (Foster et al., 2014).

In relation to the influence of mind wandering on comprehension, previous research has also explored what situational factors may play a role in the propensity for mind wandering and its influence on comprehension, specifically focusing on interest in the material, motivation to learn the material, and background knowledge in the material to be learned (e.g., Unsworth & McMillan, 2013). Therefore, Experiment 1 also investigated how interest in the lecture material, motivation to learn from the lecture video and prior knowledge of the lecture material may play a role in the propensity for mind wandering during the lecture video and in its effects on comprehension. The results from structural equation modeling revealed that interest in and prior knowledge of the lecture material contributed to mind wandering while watching the lecture video. Specifically, those who found the lecture material covered in the video more interesting mind wandered less during the lecture video, which is in line with previous studies examining the relationship between topic interest and mind wandering (Hollis & Was, 2014; Lindquist & McLean, 2011; Unsworth & McMillan, 2013) and those who indicated having more prior knowledge of the lecture material mind wandered more during the lecture video.

Furthermore, structural equation modeling showed that mind wandering accounted for performance decrements on the lecture comprehension test, providing further evidence

for the well-established disruptive effect of mind wandering on task performance, as discussed earlier. These results illustrate that mind wandering during lecture videos is disruptive on the comprehension of the lecture material, which is directly influenced by how much background knowledge an individual has prior to watching the lecture video and is indirectly influenced by how interesting an individual finds the lecture material. Those who have more prior knowledge of the lecture video seem to have the luxury of engaging in task-unrelated thoughts without impeding their comprehension of the lecture video. When an individual is not interested in the lecture material, the individual tends to mind wander more, which results in poorer comprehension of the lecture material.

To explore individual differences in the propensity for mind wandering during the lecture video, Experiment 1 mainly focused on working memory capacity, media multitasking index, frequency of dissociative experiences, mind wandering tendency, and trait mindfulness. Of these five individual differences measures, only mind wandering tendency and trait mindfulness significantly predicted the propensity for mind wandering during the lecture video. As expected, individuals who reported a greater tendency to mind wander in daily life were caught mind wandering more frequently during the experiment than those who reported a lower frequency of mind wandering in daily life, which lends further support to the association between the frequency of mind wandering in daily life and the propensity for mind wandering during laboratory tasks and to the convergent validity of the self-reported measure of the frequency of mind wandering, the MWQ (Mrazek, Phillips et al., 2013). Interestingly, however, individuals who reported high trait mindfulness were caught mind wandering during the experiment more frequently than those reporting

relatively lower levels of trait mindfulness. This finding may be perceived as contradictory to the early conceptualization of the association between trait mindfulness and the propensity for mind wandering during a demanding task (i.e., Mrazek et al., 2012); nevertheless, further scrutiny of the multiple regression model showed that the trait mindfulness variable was a suppressor variable that increased the predictive utility of the mind wandering tendency variable as an approximation for the propensity for mind wandering, rather than being an actual predictor itself. Therefore, the results of Experiment 1 regarding the predictive utility of trait mindfulness on the propensity for mind wandering are inconclusive.

Little is known about the role of trait mindfulness as a predictor of the propensity for mind wandering during a demanding task. Mrazek et al. (2012) found that trait mindfulness was negatively associated with the propensity for mind wandering during the SART, but did not report whether it predicted the propensity for mind wandering. Likewise, Mrazek, Franklin et al. (2013) provided further evidence for the negative association between trait mindfulness and the propensity for mind wandering this time during reading. The authors also found that trait mindfulness did not predict the propensity for mind wandering – only mind wandering tendency did, congruent with the current experiment. The lack of cogent evidence for the relationship between trait mindfulness and the propensity for mind wandering during demanding tasks may be attributed to the use of the MAAS as a measure of trait mindfulness. In spite of having been widely used as an indication of trait mindfulness, the MAAS may be limited in its conceptualization of mindfulness as a trait-like attribute as pointed out by Van Dam, Earleywine, and Borders (2010) and therefore may fall short of

reflecting the contemporary conceptualizations of trait mindfulness. As a result the MAAS may not be a valid measure of trait mindfulness. This presents a fruitful area of study for future research on the development and validation of a measure of trait mindfulness based on the contemporary conceptualizations of mindfulness.

A further investigation into the five individual differences measures with respect to their moderating roles in the influence of mind during the lecture video on the comprehension of lecture material revealed no individual differences in the influence of mind wandering on lecture comprehension in terms of working memory capacity, mind wandering tendency, trait mindfulness, frequency of dissociative experiences, and media multitasking frequency.

Experiment 1 demonstrated that the brief, 10-minute mindfulness intervention did not reduce mind wandering during the lecture video as might be expected from the results of Mrazek et al. (2012). Mrazek et al. showed that a similar brief, 8-minute mindfulness intervention could reduce performance markers of mind wandering during the SART. It may be that brief mindfulness interventions are effective in reducing mind wandering during such repetitive, laboratory tasks as the SART, but they may not be strong enough to induce a state of mindfulness that could enhance attentional control and reduce mind wandering during real-life sustained attention tasks (e.g., watching a lecture video). Experiment 2 was designed to examine whether this might be the case.

CHAPTER 3. EXPERIMENT 2

Experiment 1 revealed null findings regarding the hypothesized beneficial influence of the 10-minute mindfulness intervention prior to watching the lecture video on mind wandering during the lecture video and on its deleterious effects on lecture comprehension. The lack of an effect was unexpected given that a similar brief mindfulness meditation practice (8 minutes long) has been shown to lead to reductions in indirect performance markers of mind wandering during the SART (Mrazek et al., 2012). As described earlier, the SART is a go/no-go sustained attention task that requires participants to respond to frequently-presented go stimuli (e.g., letters or digits), referred to as nontargets, and to withhold response to no-go stimuli, referred to as targets (Robertson et al., 1997). When compared to nontargets, targets occur rarely. For instance, in a typical SART containing 240 trials, only 16 trials are targets. Two indices from the SART have been widely used as performance markers of mind wandering. The first index, SART errors, represents failures to refrain from responding to no-go stimuli, or targets. The second index, reaction time variability or RT CV, represents the variability in response times to go stimuli, or nontargets. SART errors are regarded as reflecting a drift of attention from the immediate task, whereas RT CV is interpreted as reflecting subtle attentional fluctuations (Cheyne et al., 2009; McVay & Kane, 2009; Mrazek et al., 2012).

Experiment 2 was modeled on Experiment 1, but it employed the SART as the attention-demanding task rather than a lecture video. It was designed as a conceptual replication of Mrazek et al. (2012, Study 2) and investigated whether the brief, guided mindfulness intervention could reduce mind wandering during the SART. It was

hypothesized that the brief mindfulness intervention would lead to reductions in performance indices of mind wandering during the SART, when compared to the control group. Because there was no difference between the listening and the no-treatment control groups in Experiment 1, only the listening group was used in Experiment 2. Also, to shorten the entire procedure, the OSPAN task was not used.

Method

Experiment 2 employed a one-factor between-subjects design with two conditions: listening and mindfulness meditation. Participants were randomly assigned to one of the two conditions. The primary dependent variables were SART errors and RT CV.

Participants

The sample size was calculated based on the effect size of the mindfulness meditation manipulation from Mrazek et al. (2012), compared to the two other conditions in the study ($d = .77$). A power analysis for differences between two independent means (mindfulness meditation vs. listening) was conducted in GPower (Faul, Erdfelder, Buchner, & Lang, 2013). The effect size was set at .77, input power at .80, alpha at .05, and allocation ratio (n_2/n_1) at 1. Results indicated that the total sample size would need to be 44 (22 participants in each group) to detect the effect with 80% power.

Participants were recruited from the Department of Psychology's undergraduate participant pool. Fifty-six students (38 females), with a mean age of 19.1 years old, participated in the experiment in exchange for course credit. There were 28 participants in each condition.

Materials

Experiment 2 used most of the materials from Experiment 1. Specifically, participants completed the same demographics questionnaire, MWQ, MMI, MAAS, DES, TMS, and the retrospective measure of mind wandering. The same audio recordings as in Experiment 1 were used in Experiment 2. Different from Experiment 1, the OSPAN task was not administered in Experiment 2. The experimental task of watching a lecture video in Experiment 1 was replaced with the SART. Similar to Mrazek et al. (2012), mind wandering probes were not used in Experiment 2. Instead, participants completed the retrospective measure of mind wandering immediately after the completion of the SART.

As discussed earlier, the SART is a go/no-go sustained attention task in which participants are shown an array of visual stimuli of a single category and are asked to respond to nontargets and to withhold response to targets. For Experiment 2, the SART experiment file used in Mrazek et al. (2012) was obtained from the corresponding author. In this version of the SART, nontargets, or go stimuli, were the capital letter O and targets, or no-go stimuli, were the capital letter Q. Participants were asked to make a response as fast as possible to O's, which were frequently presented, and to withhold response to Q's, which were rarely presented. The SART used in Mrazek et al. (2012) was composed of 240 stimuli and was completed in 10 minutes. To make the experimental task used in Experiment 2 match the experimental task used in Experiment 1 in terms of duration, the SART was modified to last for 20 minutes. This modification resulted in a total of 480 stimuli, 432 of which were nontargets (i.e., O). The remaining 48 stimuli were targets (i.e., Q). The presentation time was two seconds for all stimuli with a mask of 500 ms (i.e., a smaller

square within a larger square). The SART was divided into eight blocks of 60 stimuli, with 54 nontargets and 6 targets in each. The targets were quasi-randomly dispersed within each block.

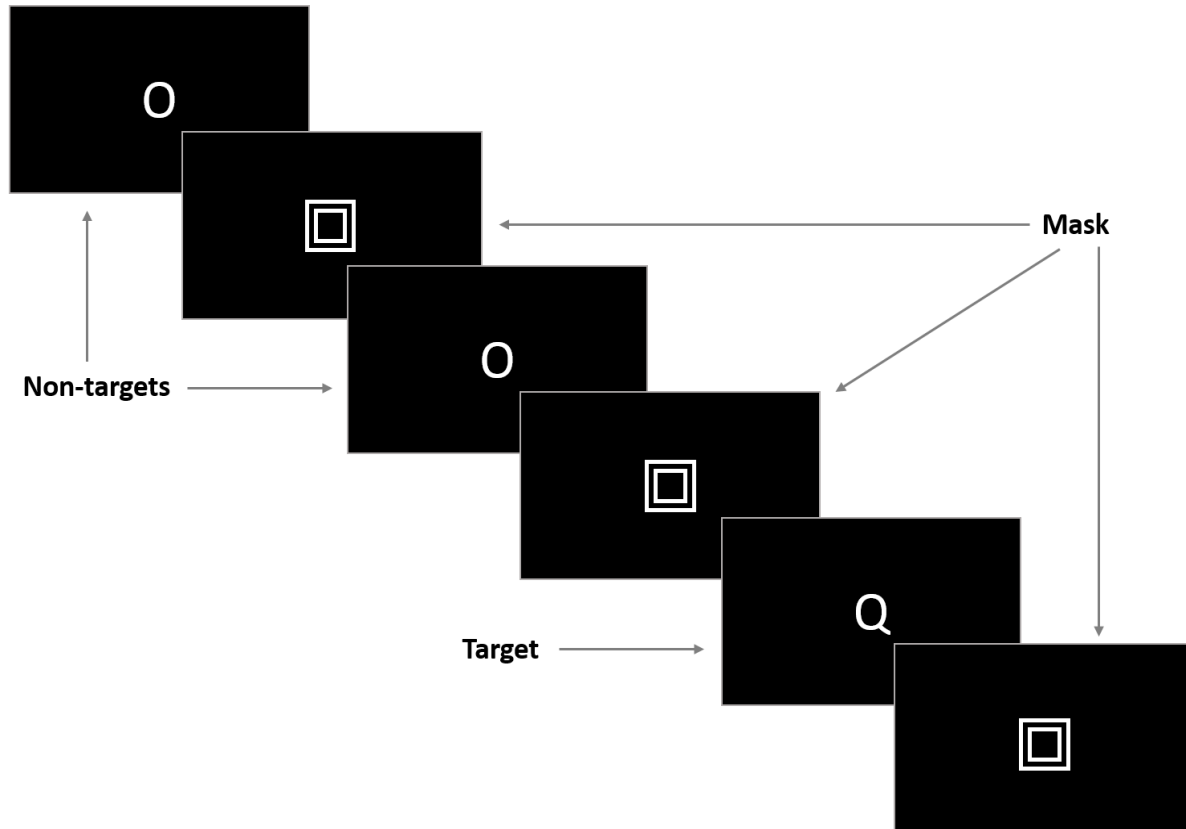

Figure 6. Example SART trials. The capital Os are nontargets and the capital Q is a target. Each stimulus was displayed for two seconds, followed by an interstimulus mask (i.e., a smaller square within larger square) shown for 500ms.

Procedures

Experiment 2 followed the same procedures as Experiment 1 except that no OSPAN task was administered, there were only two conditions (listening and mindfulness meditation), and the video task was replaced with a 20-minute version of the SART. Upon arrival to the lab, participants were briefed about the study and they completed an online Qualtrics survey that contained the demographics questionnaire, the MWQ, the MAAS, the

DES, and the MMI. Next, participants in the mindfulness group listened to and practiced the 10-minute guided mindfulness meditation, whereas the listening group listened to the audiobook for 10 minutes. After the audio phase, participants completed the TMS to report their level of state mindfulness. As in Experiment 1, the TMS was used as a manipulation check to assess whether the mindfulness manipulation influenced self-reported levels of state mindfulness. Then they were informed about the SART. Participants were asked to press the space key bar as quickly as possible when the letter was a capital O and to refrain from responding when the letter was a capital Q. Having completed 20 practice trials, participants began completing the SART. Immediately after the completion of the SART, participants completed the retrospective measure of mind wandering. At the end of the experiment, participants were debriefed about the purpose of the study.

Results

Following the descriptions of SART indices of mind wandering as proposed by Cheyne et al. (2009), failures to withhold response to NOGO stimuli were counted as SART (NOGO) errors, and RT CV was calculated as the standard deviation of RT to GO Stimuli divided by the mean RT to GO stimuli (see Appendix L for bar graphs of SART performance markers). Collectively, these indices reflect two types of task disengagement. Specifically, SART errors, or failures to withhold response to targets, indicate failures of sustained attention. RT CV indicates the variations in the speed of responses to stimuli and increased variability in response times indicates fluctuations in attention. Both indices reflect a state of generic task inattention characterized by diminished processing of perceptual input and automatic responding (Cheyne et al., 2009; Mrazek et al., 2012; Smallwood et al., 2008). Increased SART

errors and RT CV are interpreted as reflective of states of mind wandering. Bar graphs for state mindfulness levels as indexed by the TMS, SART errors, RT CV, and retrospective report of TUTs are presented in Figure 7.

As shown in Figure 7, mean values for SART errors, RT CV, retrospective self-reports of mind wandering, and state mindfulness levels across the two groups were close to each other and the confidence intervals substantially overlapped. A correlational analysis revealed that SART errors were positively associated with RT CV, $r(54) = .30, p < .05$, and with retrospective self-reports of TUTs, $r(54) = .36, p < .01$. RT CV and retrospective self-reports of TUTs were not significantly associated, $r(54) = .08, p = .571$.

To examine the effect of the brief mindfulness intervention on state mindfulness, the two groups' scores on the state mindfulness measure (i.e., the TMS) were compared via an independent-samples t test, which served as a manipulation check. Results revealed that the mindfulness group ($M = 2.27, SD = .695$) did not differ from the listening group ($M = 2.10, SD = .523$) in the level of state mindfulness as indexed by the average score on the TMS, $t(54) = 1.04, p = .153, BF_{01} = 1.44$.

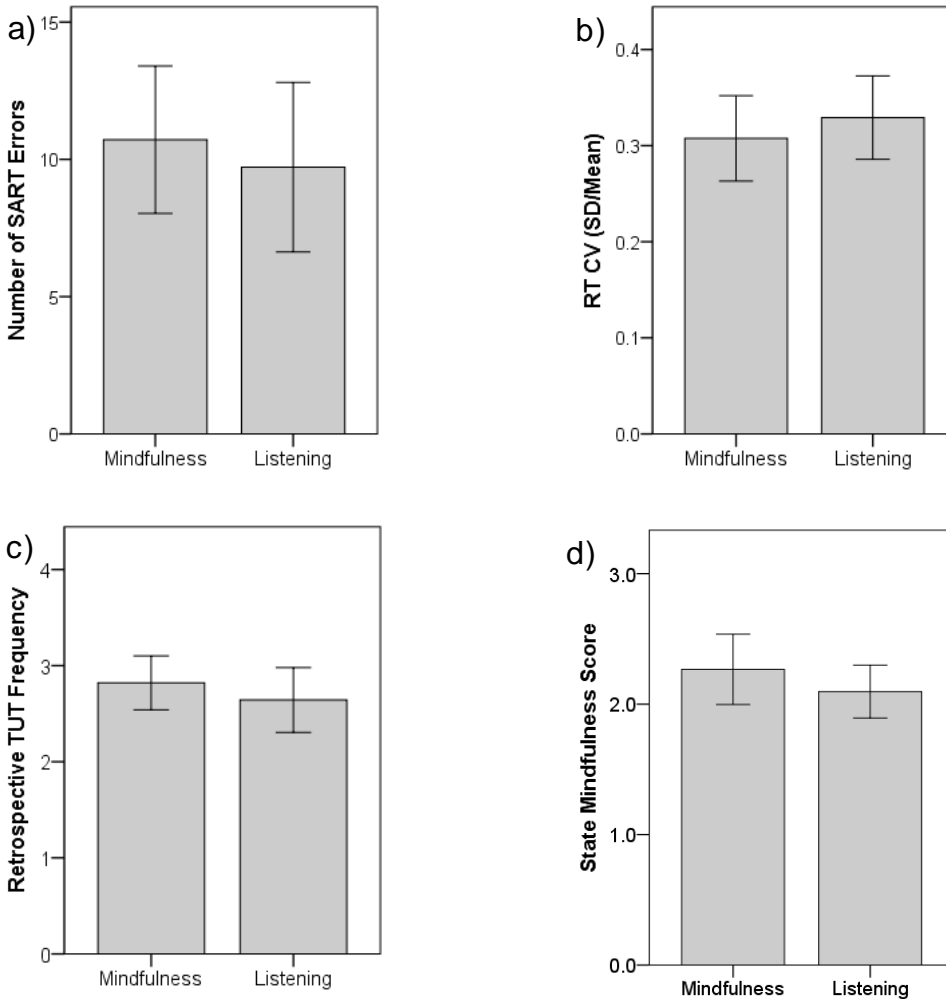

Figure 7. Bar graphs showing the results for each dependent variable as a function of condition: (a) the average number of SART Errors, (b) the average Reaction Time Coefficient of Variability, RT CV, which was calculated by dividing the standard deviation of RT by the mean RT, (c) the average score (1-5) on the retrospective report of TUTs, and (d) the average score on the Toronto Mindfulness Scale. Error bars represent 95% confidence intervals. The difference is not statistically significant in any of the graphs. The average number of SART errors and the average RT CV were comparable to those reported in Mrazek et al. (2012).

To examine the effects of the brief mindfulness intervention on the two SART indices of mind wandering, an independent-samples t test was run on each of the dependent variables. There was no significant difference between the mindfulness group ($M = 10.71$, $SD = 6.92$) and the listening group ($M = 9.71$, $SD = 7.97$) in the average number of SART errors, $t(54) = .50$, $p = .309$, $BF_{01} = 5.14$. There was no significant difference between the

mindfulness group ($M = .308, SD = .115$) and the listening group ($M = .329, SD = .112$) in RT CV, $t(54) = -.716, p = .239, BF_{01} = 2.02$. There was no significant difference between the mindfulness group ($M = 2.82, SD = .723$) and the listening group ($M = 2.64, SD = .870$) in the average frequency of retrospectively reported TUTs, $t(54) = .84, p = .204, BF_{01} = 6.16$. These results suggest that, contrary to prediction, the brief, 10-minute guided mindfulness intervention did not reduce mind wandering during the SART.

To further examine whether the increased 20-minute duration of the SART in the current experiment, as opposed to the 10-minute version of the SART used in Mrazek et al. (2012), might have precluded the replication of the effect, the SART was divided into two halves of 10 minutes. SART errors and RT CV values were calculated for the first half of the SART so that the comparisons in the current experiment matched exactly those of Mrazek et al. Next, an independent-samples t test was conducted to compare SART errors and RT CV for the first 10 minute of the SART between the mindfulness and listening groups. There was no significant difference between the mindfulness group ($M = 3.82, SD = 2.93$) and the listening group ($M = 3.93, SD = 4.33$) in the average number of 10-minute-SART errors, $t(54) = -.108, p = .457, BF_{01} = 3.42$. There was no significant difference between the mindfulness group ($M = .270, SD = .097$) and the listening group ($M = .298, SD = .111$) in RT CV during the first 10 minutes of the SART, $t(54) = -1.03, p = .155, BF_{01} = 1.45$. These results suggest that the brief mindfulness intervention led to no substantial reductions in mind wandering during the first 10 minutes of the SART either, ruling out the possibility of the doubled duration of the SART affecting the results.

A pair-wise comparison of performance indices in the first and second halves of the SART revealed that SART errors increased, $t(55) = -5.72, p < .001, BF_{10} > 200$, between the first 10-minute portion of the SART ($M = 3.88, SD = 3.66$) and the second 10-minute portion of the SART ($M = 6.34, SD = 4.39$). Likewise, the analysis showed that RT CV increased, $t(55) = -4.85, p < .001, BF_{10} > 200$, between the first 10-minute portion of the SART ($M = .284, SD = .104$) and the second 10-minute portion of the SART ($M = .342, SD = .136$). These results suggest that mind wandering increased as a function of time on task, as is typically found.

The previous analysis was further broken down to the level of task blocks. As pointed out earlier, the SART was composed of eight blocks of 60 trials. To examine the effect of condition and task block on SART errors and RT CV, a mixed ANOVA was conducted, entering task block as a within-subject repeated-measures factor with eight levels and condition as a between-subject factor.

Mauchly's test indicated that the assumption of sphericity had been violated for both SART errors, $\chi^2(27) = 48.56, p < .01$, and RT CV, $\chi^2(27) = 114.30, p < .001$. Therefore, degrees of freedom were corrected using Greenhouse-Geisser estimates of sphericity (SART errors: $\varepsilon = .80$, RT CV: $\varepsilon = .56$). The results showed that there were significant differences in the performance markers of mind wandering as a function of time on task, as indicated by a statistically significant main effect of task block in a repeated-measures ANOVA on both SART errors, $F(5.57, 300.86) = 13.94, MSE = 1.06, p < .001, \eta^2 = .205, BF_{10} > 200$, and on RT CV, $F(3.89, 210.05) = 17.67, MSE = .011, p < .001, \eta^2 = .247, BF_{10} > 200$. However, there was no significant effect of condition either on SART errors, $F(1, 54) = .251, MSE = 6.96, p = .618$, or on RT CV, $F(1, 54) = .367, MSE = .103, p = .547$. Likewise, there was no significant

interaction between condition and task block either for SART errors, $F(5.57, 300.86) = 1.93$, $p = .082$, or for RT CV, $F(3.89, 210.05) = .385$, $p = .814$.

Polynomial within-subject contrasts revealed a linear trend for the increase of SART errors, $F(1, 54) = 56.43$, $MSE = 1.27$, $p < .001$, and RT CV, $F(1, 54) = 38.42$, $MSE = .018$, $p < .001$, as a function of task block, which are illustrated in Figure 8 and Figure 9 respectively. The contrasts also revealed a quadratic trend for the increase of RT CV over the duration of the task, $F(1, 54) = 8.99$, $MSE = .006$, $p < .01$. Taken together, these results suggest that, irrespective of the condition, mind wandering increased linearly as time on task increased.

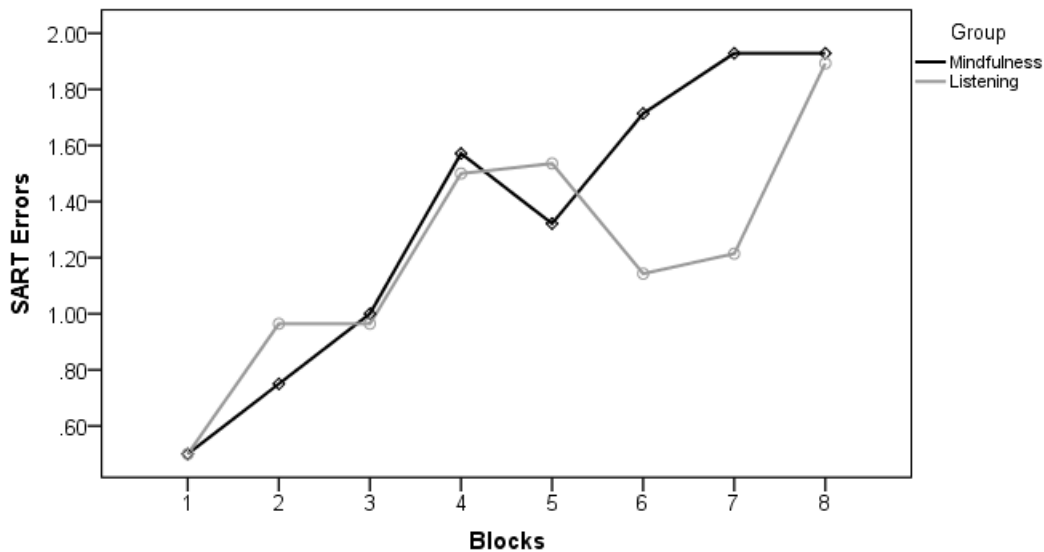

Figure 8. SART errors as a function of task block.

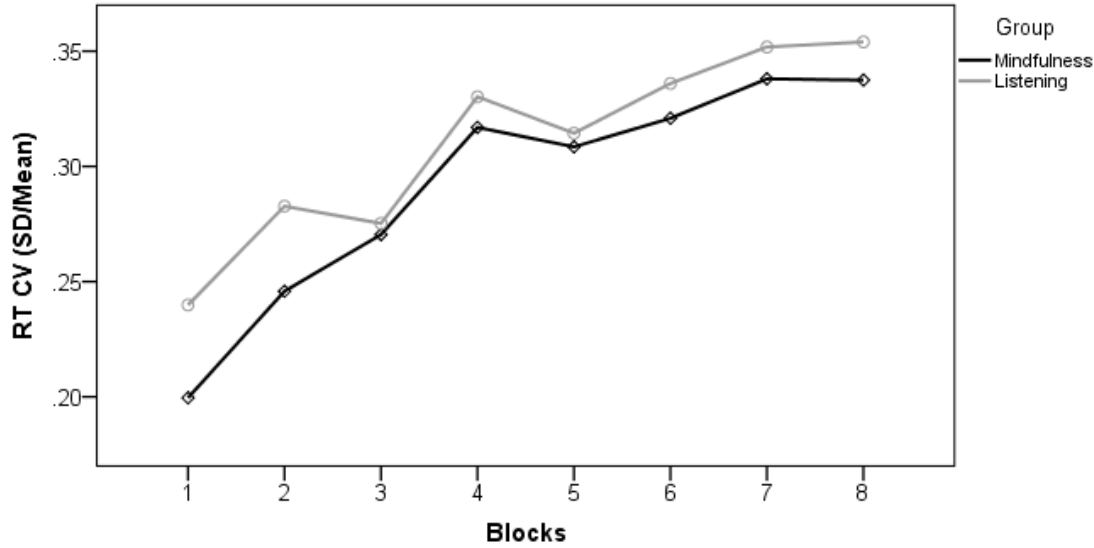

Figure 9. RT CV as a function of task block.

Discussion

In Experiment 1, a brief guided mindfulness intervention did not reduce mind wandering in participants viewing a lecture video. Experiment 2 was designed as a conceptual replication of the Mrazek et al. (2012), which demonstrated an effect of a brief mindfulness intervention on the SART, a repetitive laboratory task. Experiment 2 investigated whether the brief, 10-minute guided mindfulness intervention used in Experiment 1 could reduce mind wandering during the SART. Based on the results of Mrazek et al., it was predicted that the brief mindfulness intervention would lead to reductions in performance indices of mind wandering during the SART, when compared to the control group. Contrary to prediction, Experiment 2 failed to replicate the effect and revealed no significant differences in behavioral indices of mind wandering during the SART between the mindfulness group and the control group. These results demonstrate that the brief mindfulness intervention did not lead to substantial reductions in mind wandering during the SART, an outcome incongruent with Mrazek et al. (2012).

Although the use of guided mindfulness meditation auditory tapes such as that used in this dissertation are the most common way to induce a state of mindfulness (e.g., Erisman & Roemer, 2010; Taraban et al., 2017; Xu et al., 2017), it should be noted that Mrazek et al. (2012) used an unguided mindfulness practice. Their participants were instructed to focus attention on their breath and bring it back to their breath whenever they notice they have been mind wandering. The instructions were first displayed on the computer screen and then participants spent the next eight minutes monitoring their breath and bringing attention back to the breath when strayed away from it.

There is no apparent reason to believe that the guided versus the unguided mindfulness practice should produce different effects on mind wandering. In both cases the mindfulness meditation encourages individuals to anchor attention to a single object (e.g., one's breathing), and it is expected that this self-regulation of focused attention will lead to better attentional control. The increase in attentional control allows individuals to notice when they have strayed away from an ongoing activity more quickly and redirect attention from TUTs to the ongoing activity more quickly (Mrazek, Franklin et al., 2013; Mrazek et al., 2012). But, while Mrazek et al. (2012) showed that an eight-minute, unguided mindfulness practice could reduce performance indices of mind wandering during the SART, Experiment 2 yielded no corroborative evidence for the beneficial effect of a brief, 10-minute, guided mindfulness intervention on behavioral markers of mind wandering during the SART.

One potential explanation why Experiment 2 failed to replicate the findings of Mrazek et al. (2012) is that brief mindfulness interventions are not robust enough to always induce a mindfulness state that leads to substantial and consistent reductions in mind wandering.

There was no effect of the brief mindfulness intervention in either Experiment 1 or Experiment 2, suggesting that a brief mindfulness intervention may not be strong enough to exert immediate beneficial effects on attentional control and thus to reduce mind wandering during sustained attention tasks. Repeated and consistent practice may be needed to observe substantial improvements in the capacity to appraise the contents of thought and in the ability to focus attention.

Another potential explanation for why Experiment 2 failed to replicate the findings of Mrazek et al. (2012) is the difference between a guided and unguided brief mindfulness intervention. As already stated, there is no apparent reason for why they should differ. Nonetheless, it may be the case that an unguided, brief mindfulness intervention has a different effect from that of a guided, brief mindfulness intervention on mind wandering such that immediate reductions on mind wandering could be obtained through unguided, brief mindfulness interventions but not through guided, brief mindfulness interventions. While it could be argued that a guided, brief mindfulness intervention should be more robust than an unguided intervention, a direct replication of Mrazek et al. is needed before clearly drawing the conclusion that brief mindfulness interventions are not robust enough to produce consistent immediate beneficial effects over mind wandering. Regardless, given that not all brief mindfulness interventions appear to work, future research could investigate the effects of brief but somewhat longer-term mindfulness meditation training interventions on mind wandering (e.g., two brief interventions with practice and feedback in between). This will be discussed further in Chapter 5.

CHAPTER 4. CORRELATIONAL EXAMINATION

Experiments 1 and 2 found no evidence that the brief mindfulness meditation intervention had any beneficial effects on mind wandering. The analysis of individual differences in Experiment 1 was focused on mind wandering during the lecture video and lecture comprehension. In Experiment 2, however, an analysis of individual differences was not performed due to the relatively low number of participants. Combining the individual differences measures for participants from Experiments 1 and 2, a correlational examination was done that focused on the relationship among the individual differences measures themselves, that is, media multitasking frequency, trait mindfulness, frequency of dissociative experiences, and mind wandering tendency. As pointed out before, mindfulness and mind wandering are conceptualized as opposing constructs, and thus, trait mindfulness and mind wandering tendency are conceived as being inversely associated (Mrazek, Franklin et al., 2013; Mrazek, Phillips et al., 2013). The correlational examination further explored this relationship, taking into consideration media multitasking and frequency of dissociative experiences.

Media multitasking refers to concurrently engaging in and consuming multiple types of media (Ophir et al., 2009). In their pioneering study regarding the effect of media multitasking on attentional control, Ophir et al. (2009) devised a media multitasking index (MMI) to measure media multitasking frequency across various types of media and investigated the role of media multitasking in attentional control. The MMI was used to categorize participants into heavy media multitaskers (HMM) and light media multitaskers (LMM). Ophir et al. found that the performance of HMMs on a task-switching paradigm was

poorer than that of LMMs and that HMMs demonstrated an increased susceptibility to interference from task-irrelevant stimuli during a filtering task. Ophir et al. concluded that HMMs had a greater proclivity for bottom-up attentional control, directed by environmental stimuli, and that they tended to process information in an exploratory manner, focusing on broader aspects rather than details. In contrast, LMMs were reported to demonstrate a greater tendency for top-down attentional control, allowing them to better focus and sustain attention on a single task in the face of interference.

Subsequent studies have produced mixed results regarding this account of media multitasking and its deleterious effects on attentional control. Cain and Mitroff (2011) and Sanbonmatsu, Strayer, Medeiros-Ward, and Watson (2013) provided further support for the view that when compared to LMMs, HMMs tend to suffer from performance decrements during demanding cognitive tasks due to their wider attentional focus and decreased ability to suppress distractions. Nonetheless, Alzahabi and Becker (2013) demonstrated that HMMs outperformed their LMM counterparts in a task-switching paradigm and that the performance of HMMs and LMMs did not differ on a dual-task paradigm. Similarly, Minear, Brasher, McCurdy, Lewis, and Younggren (2013) showed that HMMs and LMMs did not differ in their ability to task-switch. Taken together, previous findings regarding the role of media multitasking in attentional control are somewhat inconclusive.

Despite these mixed results, there exists some evidence for a link between media multitasking and mind wandering (e.g., Ralph, Thomson, Cheyne, & Smilek, 2014). Ralph et al. (2014) found that media multitasking frequency was positively associated with mind wandering tendency in daily life and that it was negatively associated with trait mindfulness.

The authors also proposed and tested a plausible causal model in which the effect of media multitasking on mind wandering was fully mediated by trait mindfulness. Accordingly, this model predicted that media multitasking would lead to deficits in top-down attentional control and decreased levels of mindfulness, which would in turn result in greater propensity for mind wandering.

While this model was proposed based on correlational data, its tenets are consistent with some findings from neuroimaging studies. Specifically, Loh and Kanai (2014) observed that HMMs had smaller gray-matter density in the anterior cingulate cortex (ACC), which is strongly implicated in top-down attentional control (van Veen & Carter, 2002) and has been shown to be positively affected by mindfulness meditation training (Allan et al., 2012; Hölzel et al., 2007; Tang & Posner, 2013; Treadway & Lazer, 2010). Furthermore, it has also been argued that media multitasking may lead to increased activity in the default mode network (DMN; Ziegler, Mishra, & Gazzaley, 2015), which is implicated in mind wandering (Buckner et al., 2008; Mason et al., 2007). Given the functional connectivity between the ACC and DMN (Buckner et al., 2008), it is plausible that media multitasking may lead to lower levels of mindfulness (lessened activity in the ACC), which in turn results in greater propensity for mind wandering (greater activity in the DMN). Therefore, it was predicted that media multitasking frequency would positively predict the propensity for mind wandering through trait mindfulness.

As discussed earlier, dissociation refers to transient lapses or disruptions in the integration of experiences, thoughts, feelings, memories, and actions into consciousness (Bernstein & Putnam, 1986). Considering that dissociation reflects a form of detachment

from the present conscious experience, dissociation and mindfulness can be thought of as being inversely related such that those individuals who tend to have frequent dissociative experiences should demonstrate lower levels of mindfulness in their daily life. In fact, it has been shown that trait mindfulness and frequency of dissociative experiences were negatively associated (Walach, Buchheld, Buttenmüller, Kleinknecht, & Schmidt, 2006). Therefore, it was predicted that frequency of dissociative experiences would be negatively associated with trait mindfulness and would be positively associated with media multitasking frequency and mind wandering tendency. It was also predicted that, similar to trait mindfulness, frequency of dissociative experiences would play a mediating role in the relationship between media multitasking frequency and mind wandering tendency.

Method

Participants

Participants were the undergraduate students who participated in Experiment 1 and in Experiment 2. This resulted in a dataset containing the data from 233 participants (133 females). The mean age of these participants was 19.7.

Materials

Materials included the questionnaires used in both Experiment 1 and Experiment 2. Specifically, the MMI, MAAS, DES, and MWQ were used. The MMI is a measure of the frequency of media multitasking, the MAAS is a measure of trait mindfulness, the DES is a measure of the frequency of dissociative experiences, and the MWQ is a measure of mind wandering tendency. The MMI demonstrated good internal consistency in the present

sample (Cronbach's alpha = .92). The reliability estimates were also good for the MAAS ($\alpha = .87$), the DES ($\alpha = .91$), and the MWQ ($\alpha = .81$).

Procedures

As described earlier, participants in Experiment 1 and Experiment 2 completed the questionnaires through an online Qualtrics survey before the experimental manipulation. The questionnaire data from Experiment 1 and Experiment 2 were combined.

Results

Regarding the relationship between media multitasking and mind wandering, it was expected that trait mindfulness and frequency of dissociative experiences would mediate this relationship. Specifically, it was hypothesized that self-reports of media multitasking frequency would positively predict self-reports of mind wandering tendency through self-reports of trait mindfulness and frequency of dissociative experiences such that those who media multitask more frequently would demonstrate lower levels of trait mindfulness and higher frequency of dissociative experiences, which in turn would lead to increased mind wandering tendency. To test this parallel mediation model, a bootstrapped (10000) mediation analysis was conducted using the PROCESS macro for SPSS (Hayes, 2013). Correlations among the variables are presented in Table 13. The results of the mediation analysis for all participants are presented in Figure 10. The mediation model is reported without the frequency of dissociative experiences because it did not significantly contribute to the model.

Table 13. Correlations among individual differences measures across all participants from both experiments

Measure	<i>M (SD)</i>	1	2	3	4
1. Mind wandering tendency	3.92 (.84)	.810			
2. Trait mindfulness	3.89 (.73)	-.718**	.867		
3. Dissociative experiences	2.66 (1.44)	.288**	-.444**	.909	
4. Media multitasking frequency	2.56 (.78)	.367**	-.360**	.213**	.916

Values on the diagonal indicate the reliability estimates (Cronbach's alpha) for each individual differences measure. The mean values were comparable to previous studies for MWQ (Mrazek, Phillips et al., 2013), MAAS (Mrazek, Phillips et al., 2013), DES (Van IJzendoorn et al., 1996), and MMI (Ralph et al., 2014). $N = 232$. ** $p < .01$.

As shown in Table 13, correlations among the variables were congruent with the conceptual associations among these variables. Specifically, media multitasking frequency was positively associated with mind wandering tendency and frequency of dissociative experiences and it was negatively associated with trait mindfulness. Mind wandering tendency was negatively associated with trait mindfulness and positively associated with frequency of dissociative experiences, as expected. Lastly, trait mindfulness and frequency of dissociative experiences were negatively associated.

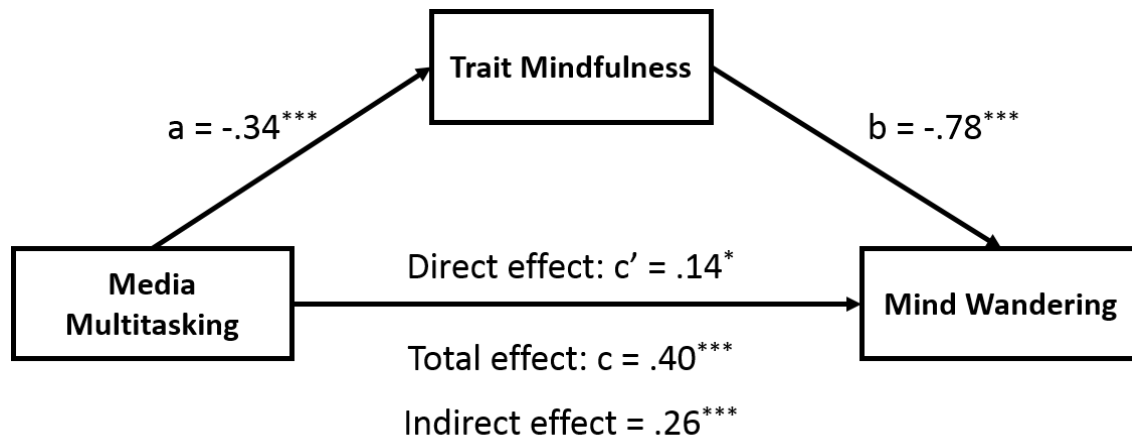

Figure 10. The mediating role of trait mindfulness in the relationship between media multitasking and mind wandering. Note that the same model was run with the frequency of dissociative experiences added as a parallel mediator. Results revealed the frequency of dissociative experiences did not significantly contribute to the model. Therefore, it was not included in the analysis and all analyses were conducted with trait mindfulness as the single mediator.

As can be seen from Figure 10, media multitasking frequency significantly predicted trait mindfulness (path a), $b = -.34$, $SE = .063$, $p < .001$, 95% CI [-.46, -.21]. Media multitasking frequency alone explained 13% of the variance in trait mindfulness, $F(1, 230) = 28.38$, $MSE = .464$, $p < .001$, $R^2 = .13$. Trait mindfulness significantly predicted mind wandering tendency (path b), $b = -.78$, $SE = .062$, $p < .001$, 95% CI [-.90, -.65], and the direct effect of media multitasking frequency on mind wandering tendency was statistically significant (path c'), $b = .14$, $SE = .054$, $p < .05$, 95% CI [.03, .24]. This model for the direct effect of media multitasking frequency on mind wandering tendency (path c'), controlling for the effect of trait mindfulness (path b) explained 53% of the variance in mind wandering tendency, $F(2, 229) = 114.07$, $MSE = .335$, $p < .001$, $R^2 = .53$. Lastly, the total effect of media multitasking on mind wandering tendency was statistically significant (path c), $b = .40$, $SE = .069$, $p < .001$, 95% CI [.26, .53]. Media multitasking frequency alone explained 14% of the variance in mind wandering tendency, $F(1, 230) = 32.47$, $MSE = .613$, $p < .001$, $R^2 = .14$. The indirect effect of media multitasking frequency on mind wandering tendency through trait mindfulness was significant as well, indirect effect = .26, $SE = .052$, $p < .001$, 95% CI [.16, .37].

Given that all paths were statistically significant, that the inclusion of trait mindfulness as a mediator led to reductions in the magnitude of the effect of media multitasking frequency on mind wandering tendency (path c' < path c), and that the indirect effect of media multitasking frequency on mind wandering tendency through trait mindfulness was significant, it can be concluded that trait mindfulness partially mediated the relationship between media multitasking frequency and mind wandering tendency. These results suggest that habitual media multitasking may lead to increased tendency to

mind wander in daily life. These results also provide support for the notion that media multitasking may lead to lower levels of mindfulness, which in turn results in greater propensity for mind wandering.

Discussion

The correlational examination investigated a potential causal relationship between media multitasking frequency and mind wandering tendency as mediated by trait mindfulness. In line with Ralph et al.'s (2014) deficit-producing hypothesis, which suggests that media multitasking results in deficits in attentional control by increasing one's susceptibility to bottom-up control of attention, the current study revealed that trait mindfulness partially mediated the relationship between media multitasking and mind wandering. This partial mediation model suggests that habitual media multitasking is associated with increased tendency to mind wander in daily life and that increased frequency of media multitasking is associated with lower levels of mindfulness, which is in turn associated with greater propensity for mind wandering. Therefore, it is plausible that heavy media multitaskers may find it onerous to prevent their minds from wandering off because they compromise top-down attentional control while frequently and consistently switching attention between multiple forms of media, diminishing their ability to stay focused on a single task.

Though based on correlation data, this causal interpretation is congruent with previous studies demonstrating heavy media multitaskers' increased susceptibility to bottom-up attentional control and superficial processing, compared to light media multitaskers (Cain & Mitroff, 2011; Ophir et al., 2009). This interpretation is also consistent

with recent findings from neuroimaging studies. Specifically, Loh and Kanai (2014) observed that HMMs had smaller gray-matter density in the ACC, which is strongly implicated in top-down attentional control (van Veen & Carter, 2002) and has been shown to be positively affected by mindfulness meditation training (Allan et al., 2012; Hölzel et al., 2007; Tang & Posner, 2013; Treadway & Lazer, 2010). Furthermore, it has also been argued that media multitasking may lead to increased activity in the DMN (Ziegler et al., 2015), which is implicated in mind wandering (Buckner et al., 2008; Mason et al., 2007). Hence, it is plausible that media multitasking may lead to lower levels of mindfulness (lessened activity in the ACC), which in turn results in greater propensity for mind wandering (greater activity in the DMN). Given that the current study tested this causal model based on correlational data, the extent to which this proposition is tenable remains an open area of investigation for future experimental and/or longitudinal studies.

CHAPTER 5. GENERAL DISCUSSION

The current dissertation set out to disentangle whether inducing a state of mindfulness through a brief mindfulness intervention prior to engaging in a sustained attention task could reduce mind wandering in the subsequent task. Given that a similar brief mindfulness intervention has been shown to lead to reductions in mind wandering during a laboratory attention task (Mrazek et al., 2012), the dissertation sought to further investigate the viability of such a brief intervention for reducing mind wandering during an ecologically valid sustained attention task. Although such brief interventions may not be as robust as long-term interventions, nor are they claimed to be, investigations utilizing brief interventions attempt to determine the extent to which brief mindfulness interventions could produce transient, positive benefits, with the aim of shedding light on immediate benefits of brief mindfulness interventions and their application to various domains, including daily life settings, work environments, education, etc.

Experiment 1 investigated the influence of a brief, 10-minute guided mindfulness intervention on mind wandering during an ecologically valid sustained attention task, i.e., learning from a lecture video. The results demonstrated that the brief mindfulness intervention had no beneficial effects on the occurrence of mind wandering during the lecture video, nor on its disruptive effects on lecture comprehension. In an attempt to conceptually replicate Mrazek et al. (2012), a previous study in the literature that guided the current dissertation, Experiment 2 investigated the influence of the 10-minute mindfulness intervention on behavioral indices of mind wandering during a laboratory sustained attention task, the SART. The results demonstrated that the brief intervention did not lead

to any substantial reductions in the performance markers of mind wandering during the SART. Collectively, the current experiments indicate that the brief, guided mindfulness intervention used in the current dissertation has no immediate beneficial effects on attentional control and mind wandering during demanding tasks.

While the current study revealed several null findings regarding the impact of the brief mindfulness intervention on mind wandering, it did yield various findings consistent with previous studies in the literature. To begin with, Experiment 1 demonstrated that mind wandering during the lecture video was the reason for performance decrements on the subsequent lecture comprehension test, providing further support for the well-established deleterious effect of mind wandering on task performance (McVay & Kane, 2012; Mrazek, Franklin et al., 2013; Smallwood et al., 2007; Smallwood et al., 2008; Reichle et al., 2010; Unsworth & McMillan, 2013; Szpunar et al., 2013). Moreover, Experiment 1 examined the roles of interest in the lecture material, motivation to learn from the lecture video, and prior knowledge of the lecture material in the propensity for mind wandering and in the influence of mind wandering on lecture comprehension. The results from structural equation modeling showed that interest in and prior knowledge of the lecture material significantly contributed to mind wandering during the lecture video. Similar to prior work on the association between topic interest and mind wandering (Hollis & Was, 2014; Lindquist & McLean, 2011; Unsworth & McMillan, 2013), greater interest in the lecture video predicted fewer mind wandering episodes during the lecture video, suggesting that individuals who found the lecture video more interesting mind wandered less during the lecture video. Also, interest in the lecture material had an indirect effect on lecture comprehension through

mind wandering. Interestingly, prior knowledge of the lecture material positively predicted the propensity for mind wandering, suggesting that individuals who had more background information on the lecture material mind wandered more during the lecture video. The indirect effect of prior knowledge on lecture comprehension through mind wandering was not significant, suggesting that the tendency of those individuals to indulge in mind wandering during the lecture video did not negatively affect their comprehension of the lecture material.

Collectively, these results show that mind wandering during lecture videos impedes the comprehension of the lecture material, that increased interest in the lecture material leads to fewer mind wandering episodes during the lecture video, and that greater prior knowledge of the lecture material affords the luxury of mind wandering without impeding the comprehension of the lecture video too much. When an individual is not interested in the lecture material, however, the individual tends to mind wander more, which in turn leads to poorer lecture comprehension. This finding regarding the role of interest in the propensity for mind wandering may be applicable to the presentation of information such that presenting information in an interesting format could reduce mind wandering when compared to a dull presentation format, which can be easily tested in future studies.

Experiment 1 also examined what individual differences may predict the propensity for mind wandering during the lecture video, and found that mind wandering tendency in daily life positively predicted the propensity for mind wandering during the lecture video. As expected, individuals with a greater tendency to mind wander in daily life were caught mind wandering more frequently during the lecture video than those individuals who

reported a lower mind wandering tendency in daily life. This provides further corroborative evidence for the association between mind wandering tendency in daily life and the propensity for mind wandering during laboratory tasks as well as for the convergent validity of the self-reported measure of mind wandering tendency, the MWQ (Mrazek, Phillips et al., 2013).

Experiment 2 demonstrated that SART errors and RT CV, the two performance markers of mind wandering during the SART, increased as a function of time on task, providing further evidence for the direct link between mind wandering and time spent on a task (Farley et al., 2013; Risko et al., 2012; Risko et al., 2013; Smallwood & Schooler, 2006). This association suggests that mind wandering increases as time on task increases. Although the ability to maintain sustained attention is remarkable, individuals can find it harder to keep attention focused on an ongoing task as time spent on the task increases, eventually leading to a drift of attention from the ongoing task to TUTs. Maintaining sustained attention and preventing mind wandering can be even more challenging when the immediate task is boring and unrewarding to the individual, as was surely the case with the SART. Considering that mind wandering results in impaired task performance, it is prudent to further explore what strategies might be useful for mitigating mind wandering during critical tasks requiring concentration, such as driving, air traffic controlling and security screening at airports, and to curtail its deleterious effects on task performance.

The current study also examined a plausible causal relationship between self-reports of media multitasking frequency and mind wandering tendency as mediated by self-reports of trait mindfulness. Congruent with the deficit-producing hypothesis (Ralph et al., 2014),

the bootstrapped mediation analysis revealed that the relationship between media multitasking and mind wandering was partially mediated by trait mindfulness. This partial mediation model suggests that habitual media multitasking is associated with an increased proclivity for mind wandering. The model also suggests that increased media multitasking frequency is associated with lower levels of trait mindfulness, which is in turn associated with increased proclivity for mind wandering. Hence, it may be the case that top-down attentional control is compromised due to frequent and consistent switching of attention between various types of media, reducing the ability to stay focused on a single task. From the perspective of the decoupling hypothesis of mind wandering (Schooler et al., 2011; Smallwood, 2011), it could be argued that in an attempt to attend to multiple types of media, heavy media multitaskers (HMM) practice repeatedly decoupling attention from a single perceptual source, increasing their proclivity for bottom-up distraction. As a result, heavy media multitaskers may also have difficulty in warding off mind wandering because of their susceptibility to distraction (Ophir et al., 2009), which is in this case self-distraction.

While this interpretation is based on correlation data and thus should be cautiously approached, its tenets are consistent with previous studies showing that when compared to light media multitaskers (LMMs), HMMs were more susceptible to bottom-up attentional control and superficial processing (Cain & Mitroff, 2011; Ophir et al., 2009). This interpretation is also supported by some recent findings from neuroimaging studies. Specifically, Loh and Kanai (2014) showed that gray-matter density in the anterior cingulate cortex (ACC), which is implicated in top-down attentional control (van Veen & Carter, 2002), was smaller for HMMs, when compared to LMMs. It has also been shown that mindfulness

meditation training positively affects the ACC (Allan et al., 2012; Hölzel et al., 2007; Tang & Posner, 2013; Treadway & Lazer, 2010). Moreover, Ziegler et al. (2015) argued that media multitasking may lead to heightened activation in the default mode network (DMN), which is mostly associated with mind wandering (Buckner et al., 2008; Mason et al., 2007). Thus, it is possible that habitual media multitasking may result in lower levels of mindfulness (lessened activity in the ACC), which in turn leads to an increased proclivity for mind wandering (greater activity in the DMN). Because this plausible causal relationship was tested using the correlational data from the current study, it is not possible to make a firm causal inference, which warrants future experimental and/or longitudinal investigations.

The results from the current study regarding the influence of the brief, 10-minute guided mindfulness intervention on mind wandering are contradictory to those from Mrazek et al. (2012). Mrazek et al. showed that a similar brief, 8-minute unguided mindfulness intervention led to substantial reductions in behavioral indices of mind wandering during the SART. Considering the null findings from Experiment 2 (a conceptual replication of the Mrazek et al. study) regarding the influence of a brief mindfulness intervention on behavioral indices of mind wandering during the SART, it is believed that the null findings from Experiment 1 are not due to the real-life task used in Experiment 1. Rather, taken together, Experiment 1 and Experiment 2 suggest that brief guided mindfulness interventions may not be sufficient to induce a mindfulness state that leads to substantial reductions in mind wandering and in its deleterious effects on task performance. Repeated and consistent practice may be needed to observe substantial improvements in attentional control and thus

in the ability to prevent one's mind from wandering off to thoughts irrelevant to an immediate task.

The failure to find an effect of the brief mindfulness intervention with the SART task was unexpected given that the task was identical to that used in Mrazek et al. (2012). As already discussed, however, the current dissertation employed a guided, brief mindfulness intervention, whereas Mrazek et al. used an unguided, brief mindfulness intervention. Thus, it is possible that guided and unguided brief mindfulness interventions differ in how they influence an individual's ability to pay attention to the present moment and to prevent mind wandering. Unguided interventions might require more effort, for example. Compared to guided brief mindfulness interventions, unguided brief mindfulness interventions might have a different impact on mind wandering such that immediate reductions in mind wandering could be obtained through unguided brief mindfulness interventions, but not through guided brief mindfulness interventions. Although it could be argued that a guided brief mindfulness intervention should produce stronger effects than an unguided intervention, the guided training did not produce an increase in state mindfulness as reflected on the TMS. Perhaps unguided training would. Perhaps unguided training helps naïve participants to become more self-aware and that allows inhibition of mind wandering. This possibility should be empirically examined via a direct replication of Mrazek et al. before concluding that brief mindfulness interventions are not robust enough to produce consistent immediate beneficial effects over mind wandering.

Previous studies have shown that longer-term mindfulness meditation training (MMT) interventions lasting from several weeks to months could lead to substantial

improvements in attentional control (Heeren et al., 2009; Jha et al., 2010; Jha et al., 2007; Sahdra et al., 2011; Zeidan et al., 2010) and executive functioning (Moore & Malinowski, 2009; Teper & Inzlicht, 2013). The observed behavioral effects of MMT on attentional control and executive functioning have also been linked to changes in the neural underpinnings of these cognitive mechanisms (Allan et al., 2012; Hölzel et al., 2007; Tang & Posner, 2013; Treadway & Lazer, 2010). Specifically, existing studies have shown an increase in the activation of the ACC, which has been implicated in directing attention and detecting conflicting information (van Veen & Carter, 2002). Increased activity in the ACC is attributed to the exertion of a top-down control to maintain attention on a target in the presence of external distractions or trains of thought conflicting with immediate task goals (van Veen & Carter, 2002). During mindfulness meditation, individuals regulate attention by selecting and focusing on a specific object and redirecting attention back to the chosen object when attention drifts off to other thoughts, feelings, or sensations. Attention regulation is commonly practiced and developed in early phases of MMT, which are mostly related to the development of focused attention.

MMT could conceivably exert its regulatory effect on mind wandering by enhancing attentional control and executive functioning, which is consistent with extant studies on neural underpinnings of MMT and mind wandering (e.g., Hasenkamp, Wilson-Mendenhall, Duncan, & Barsalou, 2012). MMT (including both short-term and longer-term interventions) has been shown to lead to reductions in the activation of the DMN (Brefczynski-Lewis, Lutz, Schaefer, Levinson, & Davidson, 2007; Brewer et al., 2011; Tang et al., 2009). The DMN is an interconnected network of brain regions that are actively recruited during rest states, or in

the absence of an external task and are implicated in mind wandering (Buckner et al., 2008; Christoff et al., 2009; Mason et al., 2007; Mittner, Hawkins, Boekel, & Forstmann, 2016). Thus, it is plausible that MMT could reduce mind wandering during a demanding task by dampening the activity in the DMN (Mrazek, Franklin et al., 2013; Mrazek et al., 2012), which in turn precludes the intrusion of TUTs into consciousness and the allocation of attentional resources to the processing of TUTs (Christoff et al., 2009; Mittner et al., 2016).

The current study indicates that further investigations into the influence of mindfulness interventions on mind wandering are warranted. For instance, future research could investigate the influence of a more thorough, but still brief, mindfulness intervention on mind wandering. Such an investigation could have participants engage in a brief mindfulness meditation and then discuss with the participants what they experienced during the meditation practice. Having ensured that they understand the importance of focusing on their breathing and of nonjudgmentally bringing attention back to their breathing whenever their minds wander off, the experimenters could have the participants engage in another brief mindfulness meditation, after which the participants could go on to the experimental task. In so doing, the empirical question is whether this type of modified brief intervention might reduce mind wandering.

Given that there was no evidence of any immediate benefits from a brief mindfulness intervention, it would be especially useful for future studies to focus on short-term mindfulness interventions (e.g., multiple practices over several days or a few weeks) and to incorporate a self-regulated training regimen that allows participants to practice mindfulness meditation repeatedly and consistently over an extended period of time, as

opposed to a one-time practice. In one such study, Mrazek, Franklin et al. (2013) showed that a two-week mindfulness training with eight 45-minute in-class sessions and 10-minute daily individual practices for the period of two weeks led to reductions in mind wandering while reading, to substantial improvements on reading comprehension and to increases in working memory capacity. Such short-term interventions could also utilize a monitoring system to track participants' progress in the training regimen. One potential way of doing so is to use smartphone-based mobile applications specifically designed for self-regulated mindfulness meditation practices such as *Headspace* (Puddicombe, 2016). Capitalizing on the affordances of smartphones, not only do such mobile applications allow participants to self-regulate their practice sessions, but they also enable researchers to monitor participants' progress.

One limitation of the current study concerns the extent to which individuals in the mindfulness meditation group could immerse in the brief meditation practice. A limitation inherently present in most contemplative studies, it is not possible to behaviorally determine the extent to which individuals are able to focus on the present moment during the meditation practice without using physiological measures. This limitation may be even more pronounced for brief meditation interventions, in which individuals have little guidance as to how well they are engaging in the meditation practice. Therefore, future studies could address this limitation by incorporating physiological measures into the experimental procedures to assess individuals' engagement level with the meditation practice. Such measures can also be useful for the purposes of providing real-time feedback to the

individuals regarding their current state of being and helping them better focus on the chosen object of attention or the anchor (i.e., one's breathing).

As pointed out earlier, it can be challenging for novice meditators to immerse in the meditation practice. Given that training studies usually employ participants with little to no experience in mindfulness meditation, future studies could devise short-term and/or longer-term interventions that provide mindfulness meditation training in virtual reality, utilizing the enriched experience of immersion afforded by virtual reality. These studies could thus investigate how meditation in virtual reality differs, if at all, from traditional training regimens in inducing a mindfulness state, in cultivating mindfulness as a trait, in improving attentional control, and in reducing mind wandering.

The recent upsurge of both academic and public interest in brief mindfulness meditation practices has resulted from well-established benefits of long-term mindfulness interventions. Accordingly, this dissertation set out to disentangle whether participants could reap the benefits of mindfulness meditation training through a brief mindfulness intervention. Despite the increasing coverage and popularity of the *outstanding* benefits of brief mindfulness meditation practices on attention in the mainstream media (e.g., Kaplan, 2016), the current study demonstrated that a brief mindfulness intervention had no immediate beneficial influence over mind wandering nor on its disruptive effects on task performance during both an ecologically valid sustained attention task, watching a lecture video, and a laboratory sustained attention task, the SART. However, the current experiment provided further evidence for the well-documented disruptive effects of mind wandering on task performance, specifically demonstrating that increased mind wandering during the

lecture video led to poorer comprehension of the lecture video material. Future research should focus on investigating the effects of more thorough mindfulness interventions on mind wandering during demanding tasks that require concentration, whose outcomes can have invaluable implications for various human-computer interaction contexts such as air traffic controlling and security screening. Given the widespread adoption and use of various digital technologies (e.g., smartphones and wearable devices) as platforms to deliver behavioral and psychological interventions, the outcomes of such investigations into more thorough mindfulness interventions might inform the design and development of intervention technologies to help individuals better focus whenever they need to do so.

REFERENCES

- Allen, M., Dietz, M., Blair, K. S., van Beek, M., Rees, G., Vestergaard-Poulsen, P., ... & Roepstorff, A. (2012). Cognitive-affective neural plasticity following active-controlled mindfulness intervention. *The Journal of Neuroscience*, *32*(44), 15601-15610.
- Alzahabi, R., & Becker, M. W. (2013). The association between media multitasking, task-switching, and dual-task performance. *Journal of Experimental Psychology: Human Perception and Performance*, *39*(5), 1485.
- Antrobus, J. S., Singer, J. L., & Greenberg, S. (1966). Studies in the stream of consciousness: experimental enhancement and suppression of spontaneous cognitive processes. *Perceptual and Motor Skills*, *23*(2), 399-417.
- Baddeley, A. (2012). Working memory: theories, models, and controversies. *Annual review of psychology*, *63*, 1-29.
- Baer, R. A., Smith, G. T., & Allen, K. B. (2004). Assessment of mindfulness by self-report the Kentucky inventory of mindfulness skills. *Assessment*, *11*(3), 191-206.
- Baird, B., Smallwood, J., Lutz, A., & Schooler, J. W. (2014). The decoupled mind: mind-wandering disrupts cortical phase-locking to perceptual events. *Journal of Cognitive Neuroscience*, *26*(11), 2596-2607.
- Barron, E., Riby, L. M., Greer, J., & Smallwood, J. (2011). Absorbed in thought the effect of mind wandering on the processing of relevant and irrelevant events. *Psychological science*.
- Bernstein, E. M., & Putnam, F. W. (1986). Development, reliability, and validity of a dissociation scale. *The Journal of nervous and mental disease*, *174*(12), 727-735.
- Bishop, S. R., Lau, M., Shapiro, S., Carlson, L., Anderson, N. D., Carmody, J., ... & Devins, G. (2004). Mindfulness: A proposed operational definition. *Clinical psychology: Science and practice*, *11*(3), 230-241.
- Bodhi, B. (2011). What does mindfulness really mean? A canonical perspective. *Contemporary Buddhism*, *12*(01), 19-39.
- Brefczynski-Lewis, J. A., Lutz, A., Schaefer, H. S., Levinson, D. B., & Davidson, R. J. (2007). Neural correlates of attentional expertise in long-term meditation practitioners. *Proceedings of the national Academy of Sciences*, *104*(27), 11483-11488.
- Brewer, J. A., Worhunsky, P. D., Gray, J. R., Tang, Y. Y., Weber, J., & Kober, H. (2011). Meditation experience is associated with differences in default mode network activity and connectivity. *Proceedings of the National Academy of Sciences*, *108*(50), 20254-20259.

- Brewin, C. R., & Smart, L. (2005). Working memory capacity and suppression of intrusive thoughts. *Journal of behavior therapy and experimental psychiatry*, 36(1), 61-68.
- Brown, K. W., & Ryan, R. M. (2003). The benefits of being present: mindfulness and its role in psychological well-being. *Journal of personality and social psychology*, 84(4), 822-848.
- Buckner, R. L., Andrews-Hanna, J. R., & Schacter, D. L. (2008). The brain's default network. *Annals of the New York Academy of Sciences*, 1124(1), 1-38.
- Bunce, D. M., Flens, E. A., & Neiles, K. Y. (2010). How long can students pay attention in class? A study of student attention decline using clickers. *Journal of Chemical Education*, 87(12), 1438-1443.
- Cain, M. S., & Mitroff, S. R. (2011). Distractor filtering in media multitaskers. *Perception*, 40(10), 1183-1192.
- Cameron, P., & Giuntoli, D. (1972). Consciousness Sampling in the College Classroom or Is Anybody Listening?. *Intellect*, 101(2343), 63-4.
- Carriere, J. S., Cheyne, J. A., & Smilek, D. (2008). Everyday attention lapses and memory failures: The affective consequences of mindlessness. *Consciousness and cognition*, 17(3), 835-847.
- Cheyne, J. A., Carriere, J. S., Solman, G. J., & Smilek, D. (2011). Challenge and error: Critical events and attention-related errors. *Cognition*, 121(3), 437-446.
- Cheyne, J. A., Solman, G. J., Carriere, J. S., & Smilek, D. (2009). Anatomy of an error: A bidirectional state model of task engagement/disengagement and attention-related errors. *Cognition*, 111(1), 98-113.
- Chiesa, A., Calati, R., & Serretti, A. (2011). Does mindfulness training improve cognitive abilities? A systematic review of neuropsychological findings. *Clinical psychology review*, 31(3), 449-464.
- Christoff, K., Gordon, A. M., Smallwood, J., Smith, R., & Schooler, J. W. (2009). Experience sampling during fMRI reveals default network and executive system contributions to mind wandering. *Proceedings of the National Academy of Sciences*, 106(21), 8719-8724.
- Chun, M. M., Golomb, J. D., & Turk-Browne, N. B. (2011). A taxonomy of external and internal attention. *Annual review of psychology*, 62, 73-101.
- Cunningham, S., Scerbo, W., & Freeman, F. (2000). The electrocortical correlates of daydreaming during vigilance tasks. *The Journal of Mental Imagery*, 24(1-2), 61-72.
- Davidson, R. J., & Kaszniak, A. W. (2015). Conceptual and methodological issues in research on mindfulness and meditation. *American Psychologist*, 70(7), 581.

- Dehaene, S., Posner, M. I., & Tucker, D. M. (1994). Localization of a neural system for error detection and compensation. *Psychological Science*, 303-305.
- Duke University (Producer). (2016, January 12). Homeostasis and Fluid Compartments. [Video file]. Retrieved from <https://www.coursera.org/learn/physiology>.
- Engle, R. W., & Kane, M. J. (2004). Executive attention, working memory capacity, and a two-factor theory of cognitive control. In B. Ross (Ed.), *The psychology of learning and motivation* (pp. 145–199). New York, NY: Academic Press.
- Erisman, S. M., & Roemer, L. (2010). A preliminary investigation of the effects of experimentally induced mindfulness on emotional responding to film clips. *Emotion*, 10(1), 72-82.
- Eysenck, M. W., & Keane, M. T. (2015). *Cognitive psychology: A student's handbook*. Taylor & Francis.
- Fan, J., McCandliss, B. D., Sommer, T., Raz, A., & Posner, M. I. (2002). Testing the efficiency and independence of attentional networks. *Journal of Cognitive Neuroscience*, 14(3), 340-347.
- Farley, J., Risko, E. F., & Kingstone, A. (2013). Everyday attention and lecture retention: the effects of time, fidgeting, and mind wandering. *Frontiers in psychology*, 4.
- Faul, F., Erdfelder, E., Buchner, A., & Lang, A.-G. (2013). G*Power Version 3.1.7 [computer software]. Universität Kiel, Germany. Retrieved from <http://www.psych.uni-duesseldorf.de/abteilungen/aap/gpower3/download-and-register>
- Field, A. (2013). *Discovering statistics using IBM SPSS statistics*. Sage.
- Foster, J. L., Shipstead, Z., Harrison, T. L., Hicks, K. L., Redick, T. S., & Engle, R. W. (2015). Shortened complex span tasks can reliably measure working memory capacity. *Memory & cognition*, 43(2), 226-236.
- Foulsham, T., Farley, J., & Kingstone, A. (2013). Mind wandering in sentence reading: Decoupling the link between mind and eye. *Canadian Journal of Experimental Psychology/Revue canadienne de psychologie expérimentale*, 67(1), 51.
- Franklin, M. S., Broadway, J. M., Mrazek, M. D., Smallwood, J., & Schooler, J. W. (2013). Window to the wandering mind: Pupillometry of spontaneous thought while reading. *The Quarterly Journal of Experimental Psychology*, 66(12), 2289-2294.
- Gard, T., Hölzel, B. K., Sack, A. T., Hempel, H., Lazar, S. W., Vaitl, D., & Ott, U. (2012). Pain attenuation through mindfulness is associated with decreased cognitive control and increased sensory processing in the brain. *Cerebral Cortex*, 22(11), 2692-2702.

- Geerligs, T. (1994). Students' thoughts during problem-based small-group discussions. *Instructional science*, 22(4), 269-278.
- Geraerts, E., Merckelbach, H., Jelicic, M., & Habets, P. (2007). Suppression of intrusive thoughts and working memory capacity in repressive coping. *The American journal of psychology*, 205-218.
- Gethin, R. (2011). On some definitions of mindfulness. *Contemporary Buddhism*, 12(01), 263-279.
- Giambra, L. M. (1993). The influence of aging on spontaneous shifts of attention from external stimuli to the contents of consciousness. *Experimental Gerontology*, 28(4), 485-492.
- Giambra, L. M. (1995). A laboratory based method for investigating influences on switching attention to task unrelated imagery and thought. *Consciousness and Cognition*, 4(1), 1-21.
- Giambra, L. M., & Grodsky, A. (1989). Task-unrelated images and thoughts while reading. In *Imagery* (pp. 27-31). Springer US.
- Grant, J. A., Courtemanche, J., Duerden, E. G., Duncan, G. H., & Rainville, P. (2010). Cortical thickness and pain sensitivity in zen meditators. *Emotion*, 10(1), 43.
- Grossman, P., & Van Dam, N. T. (2011). Mindfulness, by any other name...: trials and tribulations of sati in western psychology and science. *Contemporary Buddhism*, 12(01), 219-239.
- Hasenkamp, W., Wilson-Mendenhall, C. D., Duncan, E., & Barsalou, L. W. (2012). Mind wandering and attention during focused meditation: a fine-grained temporal analysis of fluctuating cognitive states. *Neuroimage*, 59(1), 750-760.
- Hayes, A. F. (2013). *Introduction to mediation, moderation, and conditional process analysis: A regression-based approach*. New York: Guilford Press.
- Heeren, A., Van Broeck, N., & Philippot, P. (2009). The effects of mindfulness on executive processes and autobiographical memory specificity. *Behaviour Research and Therapy*, 47(5), 403-409.
- Hollis, R. B., & Was, C. A. (2014). Mind Wandering and Online Learning: How Working Memory, Interest, and Mind Wandering Impact Learning from Videos. *Proceedings of the 25th Annual Cognitive Science Society*, 2014(1), 3084-89
- Hölzel, B. K., Ott, U., Hempel, H., Hackl, A., Wolf, K., Stark, R., & Vaitl, D. (2007). Differential engagement of anterior cingulate and adjacent medial frontal cortex in adept meditators and non-meditators. *Neuroscience letters*, 421(1), 16-21.

- Hoogland, A. I. (2011). *Mindfulness meditation and mind wandering*. Unpublished Master's Thesis, Wake Forest University, Winston-Salem, North Carolina. Retrieved from <https://wakespace.lib.wfu.edu/handle/10339/36438>
- James, W. (1890). *The principles of psychology* New York. *Holt and company*.
- Jarosz, A. F., & Wiley, J. (2014). What are the odds? A practical guide to computing and reporting Bayes factors. *The Journal of Problem Solving*, 7(1), 2.
- JASP Team (2016). JASP (Version 0.7.5.5) [Computer software].
- Jha, A. P., Krompinger, J., & Baime, M. J. (2007). Mindfulness training modifies subsystems of attention. *Cognitive, Affective, & Behavioral Neuroscience*, 7(2), 109-119.
- Jha, A. P., Stanley, E. A., Kiyonaga, A., Wong, L., & Gelfand, L. (2010). Examining the protective effects of mindfulness training on working memory capacity and affective experience. *Emotion*, 10(1), 54.
- Kabat-Zinn, J. (1994). *Wherever you go, there you are: Mindfulness meditation in everyday life*. Hyperion.
- Kabat-Zinn, J. (2005). *Coming to our senses: Healing ourselves and the world through mindfulness*. Hachette, UK.
- Kabat-Zinn, J. (2014). *Sitting Meditation 1. On Guided Mindfulness Meditation Series 2* [CD]. Louisville, Colorado: Sounds True.
- Kam, J. W., Dao, E., Farley, J., Fitzpatrick, K., Smallwood, J., Schooler, J. W., & Handy, T. C. (2011). Slow fluctuations in attentional control of sensory cortex. *Journal of Cognitive Neuroscience*, 23(2), 460-470.
- Kane, M. J., & Engle, R. W. (2002). The role of prefrontal cortex in working-memory capacity, executive attention, and general fluid intelligence: An individual-differences perspective. *Psychonomic Bulletin & Review*, 9, 637– 671. doi:10.3758/BF03196323
- Kane, M. J., Brown, L. E., McVay, J. C., Silvia, P. J., Myin-Germeys, I., & Kwapil, T. R. (2007). For whom the mind wanders, and when: An experience-sampling study of working memory and executive control in daily life. *Psychological Science*, 18, 614–621
- Kaplan, E. (2016, September 22). How To Reshape Your Brain and Improve Your Life in Just 5 Minutes a Day. Retrieved from http://www.huffingtonpost.com/elle-kaplan/how-to-reshape-your-brain_b_12102308.html
- Killingsworth, M. A., & Gilbert, D. T. (2010). A wandering mind is an unhappy mind. *Science*, 330(6006), 932-932.
- Klinger E. (1971). *Structure and functions of fantasy*. New York: Wiley.

- Klinger, E. (1999). Thought flow: Properties and mechanisms underlying shifts in content. In J. A. Singer & P. Salovey (Eds.), *At play in the fields of consciousness: Essays in the honour of Jerome L. Singer* (pp. 29–50). Mahwah, NJ: Erlbaum.
- Klinger, E. (2013). Goal commitments and the content of thoughts and dreams: Basic principles. *Frontiers in Psychology, 4*, 1-17.
- Lau, M. A., Bishop, S. R., Segal, Z. V., Buis, T., Anderson, N. D., Carlson, L., ... & Devins, G. (2006). The Toronto mindfulness scale: Development and validation. *Journal of clinical psychology, 62*(12), 1445-1468.
- Levinson, D. B., Smallwood, J., & Davidson, R. J. (2012). The persistence of thought evidence for a role of working memory in the maintenance of task-unrelated thinking. *Psychological Science, 23*(4), 375-380.
- Lindquist, S. I., & McLean, J. P. (2011). Daydreaming and its correlates in an educational environment. *Learning and Individual Differences, 21*(2), 158-167.
- Lutz, A., Slagter, H. A., Dunne, J. D., & Davidson, R. J. (2008). Attention regulation and monitoring in meditation. *Trends in cognitive sciences, 12*(4), 163-169.
- Manly, T., Robertson, I. H., Galloway, M., & Hawkins, K. (1999). The absent mind: Further investigations of sustained attention to response. *Neuropsychologia, 37*, 661–670.
- Mason, M. F., Norton, M. I., Van Horn, J. D., Wegner, D. M., Grafton, S. T., & Macrae, C. N. (2007). Wandering minds: the default network and stimulus-independent thought. *Science, 315*(5810), 393-395.
- Matthews, G., Joyner, L., Gilliland, K., Campbell, S., Huggins, J., & Falconer, S. (1999). Validation of a comprehensive stress state questionnaire: Towards a state “big three”? In I. Mervielde, I.J. Deary, F. DeFruyt, & F. Ostendorf (Eds.), *Personality psychology in Europe* (Vol. 7, pp. 335–350). Tilburg, The Netherlands: Tilburg University Press.
- McVay, J. C., & Kane, M. J. (2009). Conducting the train of thought: working memory capacity, goal neglect, and mind wandering in an executive-control task. *Journal of Experimental Psychology: Learning, Memory, and Cognition, 35*(1), 196.
- McVay, J. C., & Kane, M. J. (2010). Does mind wandering reflect executive function or executive failure? Comment on Smallwood and Schooler (2006) and Watkins (2008). *Psychological Bulletin, 136*, 188 – 197.
- McVay, J. C., & Kane, M. J. (2012a). Drifting from slow to “D’oh!”: Working memory capacity and mind wandering predict extreme reaction times and executive control errors. *Journal of Experimental Psychology: Learning, Memory, and Cognition, 38*, 525– 549.

- McVay, J. C., & Kane, M. J. (2012b). Why does working memory capacity predict variation in reading comprehension? On the influence of mind wandering and executive attention. *Journal of Experimental Psychology: General*, 141, 302–320.
- McVay, J. C., Kane, M. J., & Kwapil, T. R. (2009). Tracking the train of thought from the laboratory into everyday life: An experience-sampling study of mind wandering across controlled and ecological contexts. *Psychonomic bulletin & review*, 16(5), 857-863.
- Minear, M., Brasher, F., McCurdy, M., Lewis, J., & Younggren, A. (2013). Working memory, fluid intelligence, and impulsiveness in heavy media multitaskers. *Psychonomic bulletin & review*, 20(6), 1274-1281.
- Mishra, J., Anguera, J. A., Ziegler, D. A., & Gazzaley, A. (2013). A cognitive framework for understanding and improving interference resolution in the brain. *Progress in brain research*, 207, 351.
- Mittner, M., Hawkins, G. E., Boekel, W., & Forstmann, B. U. (2016). A neural model of mind wandering. *Trends in Cognitive Sciences*, 20(8), 570-578.
- Mooneyham, B. W., & Schooler, J. W. (2013). The costs and benefits of mind-wandering: a review. *Canadian Journal of Experimental Psychology/Revue canadienne de psychologie expérimentale*, 67(1), 11-18.
- Moore, A., & Malinowski, P. (2009). Meditation, mindfulness and cognitive flexibility. *Consciousness and cognition*, 18(1), 176-186.
- Mrazek, M. D., Franklin, M. S., Phillips, D. T., Baird, B., & Schooler, J. W. (2013). Mindfulness training improves working memory capacity and GRE performance while reducing mind wandering. *Psychological Science*, 776-781.
- Mrazek, M. D., Phillips, D. T., Franklin, M. S., Broadway, J. M., & Schooler, J. W. (2013). Young and restless: validation of the Mind-Wandering Questionnaire (MWQ) reveals disruptive impact of mind-wandering for youth. *Frontiers in psychology*, 4, 560.
- Mrazek, M. D., Smallwood, J., & Schooler, J. W. (2012). Mindfulness and mind-wandering: finding convergence through opposing constructs. *Emotion*, 12(3), 442.
- Ophir, E., Nass, C., & Wagner, A. D. (2009). Cognitive control in media multitaskers. *Proceedings of the National Academy of Sciences*, 106(37), 15583-15587.
- Oswald, F. L., McAbee, S. T., Redick, T. S., & Hambrick, D. Z. (2015). The development of a short domain-general measure of working memory capacity. *Behavior Research Methods*, 47(4), 1343-1355
- Psychology Software Tools, Inc. [E-Prime 2.0]. (2012). Retrieved from <http://www.pstnet.com>.

- Puddicombe, A. (2016). *The headspace guide to meditation and mindfulness: How mindfulness can change your life in ten minutes a day*. New York City, NY: St. Martin's Griffin
- Ralph, B. C., Thomson, D. R., Cheyne, J. A., & Smilek, D. (2014). Media multitasking and failures of attention in everyday life. *Psychological research*, 78, 661-669.
- Reichle, E. D., Reineberg, A. E., & Schooler, J. W. (2010). Eye movements during mindless reading. *Psychological Science*, 21(9), 1300-1310.
- Reichle, E. D., Reineberg, A. E., & Schooler, J. W. (2010). Eye movements during mindless reading. *Psychological Science*, 21, 1300-1310. doi:10.1177/0956797610378686
- Risko, E. F., Anderson, N., Sarwal, A., Engelhardt, M., & Kingstone, A. (2012). Everyday attention: variation in mind wandering and memory in a lecture. *Applied Cognitive Psychology*, 26(2), 234-242.
- Risko, E. F., Buchanan, D., Medimorec, S., & Kingstone, A. (2013). Everyday attention: mind wandering and computer use during lectures. *Computers & Education*, 68, 275-283.
- Robertson, I. H., Manly, T., Andrade, J., Baddeley, B. T., & Yiend, J. (1997). 'Oops!:' Performance correlates of everyday attentional failures in traumatic brain injured and normal subjects. *Neuropsychologia*, 35(6), 747-758.
- Rowling, J. K. (1999). *Harry Potter and the Sorcerer's Stone*. Broadway, New York.
- Rummel, J., & Boywitt, C. D. (2014). Controlling the stream of thought: Working memory capacity predicts adjustment of mind-wandering to situational demands. *Psychonomic bulletin & review*, 21(5), 1309-1315.
- Sahdra, B. K., MacLean, K. A., Ferrer, E., Shaver, P. R., Rosenberg, E. L., Jacobs, T. L., ... & Mangun, G. R. (2011). Enhanced response inhibition during intensive meditation training predicts improvements in self-reported adaptive socioemotional functioning. *Emotion*, 11(2), 299-312.
- Sanbonmatsu, D. M., Strayer, D. L., Medeiros-Ward, N., & Watson, J. M. (2013). Who multi-tasks and why? Multi-tasking ability, perceived multi-tasking ability, impulsivity, and sensation seeking. *PloS one*, 8(1), e54402.
- Sayette, M. A., Reichle, E. D., & Schooler, J. W. (2009). Lost in the sauce the effects of alcohol on mind wandering. *Psychological Science*, 20(6), 747-752.
- Sayette, M. A., Schooler, J. W., & Reichle, E. D. (2010). Out for a smoke: The impact of cigarette craving on zoning out during reading. *Psychological science*, 21(1), 26-30.
- Schacter, D. L., & Szpunar, K. K. (2015). Enhancing attention and memory during video-recorded lectures. *Scholarship of Teaching and Learning in Psychology*, 1(1), 60.

- Schooler, J. W. (2002). Re-representing consciousness: Dissociations between experience and meta-consciousness. *Trends in cognitive sciences*, 6(8), 339-344.
- Schooler, J. W., Reichle, E. D., & Halpern, D. V. (2005). Zoning-out during reading: Evidence for dissociations between experience and meta-consciousness. In D. T. Levin (Ed.), *Thinking and seeing: Visual metacognition in adults and children* (pp. 204-226). Cambridge, MA: MIT Press.
- Schooler, J. W., Smallwood, J., Christoff, K., Handy, T. C., Reichle, E. D., & Sayette, M. A. (2011). Meta-awareness, perceptual decoupling and the wandering mind. *Trends in cognitive sciences*, 15(7), 319-326.
- Sedlmeier, P., Eberth, J., Schwarz, M., Zimmermann, D., Haarig, F., Jaeger, S., & Kunze, S. (2012). The psychological effects of meditation: A meta-analysis. *Psychological bulletin*, 138(6), 1139-1171.
- Seeley, W. W., Menon, V., Schatzberg, A. F., Keller, J., Glover, G. H., Kenna, H., ... & Greicius, M. D. (2007). Dissociable intrinsic connectivity networks for salience processing and executive control. *The Journal of neuroscience*, 27(9), 2349-2356.
- Smallwood, J. (2013). Distinguishing how from why the mind wanders: a process-occurrence framework for self-generated mental activity. *Psychological Bulletin*, 139(3), 519.
- Smallwood, J. M., Baracaia, S. F., Lowe, M., & Obonsawin, M. (2003). Task unrelated thought whilst encoding information. *Consciousness and cognition*, 12(3), 452-484.
- Smallwood, J., & Schooler, J. W. (2006). The restless mind. *Psychological bulletin*, 132(6), 946.
- Smallwood, J., & Schooler, J. W. (2015). The science of mind wandering: empirically navigating the stream of consciousness. *Annual review of psychology*, 66, 487-518.
- Smallwood, J., Beach, E., Schooler, J. W., & Handy, T. C. (2008). Going AWOL in the brain: Mind wandering reduces cortical analysis of external events. *Journal of cognitive neuroscience*, 20(3), 458-469.
- Smallwood, J., Brown, K. S., Tipper, C., Giesbrecht, B., Franklin, M. S., Mrazek, M. D., ... & Schooler, J. W. (2011). Pupillometric evidence for the decoupling of attention from perceptual input during offline thought. *PloS one*, 6(3), e18298.
- Smallwood, J., Davies, J.B., Heim, D., Finnigan, F., Sudberry, M., O'Connor, R., & Obonsawin, M. (2004). Subjective experience and the attentional lapse: Task engagement and disengagement during sustained attention. *Consciousness and Cognition*, 13, 657-690.
- Smallwood, J., Fishman, D. J., & Schooler, J. W. (2007). Counting the cost of an absent mind: Mind wandering as an underrecognized influence on educational performance. *Psychonomic Bulletin & Review*, 14(2), 230-236.

- Smallwood, J., McSpadden, M., & Schooler, J. W. (2007). The lights are on but no one's home: Meta-awareness and the decoupling of attention when the mind wanders. *Psychonomic Bulletin & Review*, *14*(3), 527-533.
- Smallwood, J., McSpadden, M., & Schooler, J. W. (2008). When attention matters: The curious incident of the wandering mind. *Memory & Cognition*, *36*(6), 1144-1150.
- Smallwood, J., McSpadden, M., Luus, B., & Schooler, J. (2008). Segmenting the stream of consciousness: The psychological correlates of temporal structures in the time series data of a continuous performance task. *Brain and Cognition*, *66*, 50-56. doi:10.1016/j.bandc.2007.05.004
- Smallwood, J., O'Connor, R.C., & Heim, D. (2005). Rumination, dysphoria, and subjective experience. *Imagination, Cognition and Personality*, *24*, 355-367.
- Smallwood, J., Riby, L., Heim, D., & Davies, J. B. (2006). Encoding during the attentional lapse: Accuracy of encoding during the semantic sustained attention to response task. *Consciousness and Cognition*, *15*(1), 218-231.
- Smilek, D., Carriere, J. S., & Cheyne, J. A. (2010). Out of mind, out of sight eye blinking as indicator and embodiment of mind wandering. *Psychological Science*, *21*(6), 786-789.
- Smith, R. L., Ager, J. W., & Williams, D. L. (1992). Suppressor variables in multiple regression/correlation. *Educational and Psychological measurement*, *52*(1), 17-29.
- Stawarczyk, D., Majerus, S., Maj, M., Van der Linden, M., & D'Argembeau, A. (2011). Mind-wandering: phenomenology and function as assessed with a novel experience sampling method. *Acta psychologica*, *136*(3), 370-381.
- Stuart, J., & Rutherford, R. J. D. (1978). Medical student concentration during lectures. *The lancet*, *312*(8088), 514-516.
- Szpunar, K. K., Khan, N. Y., & Schacter, D. L. (2013). Interpolated memory tests reduce mind wandering and improve learning of online lectures. *Proceedings of the National Academy of Sciences*, *110*(16), 6313-6317.
- Szpunar, K. K., Moulton, S. T., & Schacter, D. L. (2013). Mind wandering and education: from the classroom to online learning. *Frontiers in psychology*, *4*.
- Tang, Y. Y., & Posner, M. I. (2013). Tools of the trade: Theory and method in mindfulness neuroscience. *Social Cognitive and Affective Neuroscience*, *8*(1), 118-120.
- Tang, Y. Y., Lu, Q., Geng, X., Stein, E. A., Yang, Y., & Posner, M. I. (2010). Short-term meditation induces white matter changes in the anterior cingulate. *Proceedings of the National Academy of Sciences*, *107*(35), 15649-15652.

- Tang, Y. Y., Ma, Y., Fan, Y., Feng, H., Wang, J., Feng, S., ... & Zhang, Y. (2009). Central and autonomic nervous system interaction is altered by short-term meditation. *Proceedings of the national Academy of Sciences*, *106*(22), 8865-8870.
- Taraban, O., Heide, F., Woollacott, M., & Chan, D. (2017). The effects of a mindful listening task on mind-wandering. *Mindfulness*, *8*, 433-443.
- Teper, R., & Inzlicht, M. (2013). Meditation, mindfulness and executive control: the importance of emotional acceptance and brain-based performance monitoring. *Social Cognitive and Affective Neuroscience*, *8*(1), 85-92.
- Thompson, F. T., & Levine, D. U. (1997). Examples of easily explainable suppressor variables in multiple regression research. *Multiple Linear Regression Viewpoints*, *24*(1), 11-13.
- Treadway, M. T., & Lazar, S. W. (2010). Meditation and neuroplasticity: Using mindfulness to change the brain. In R. A. Baer (Ed.), *Assessing mindfulness and acceptance processes in clients: Illuminating the theory and practice of change* (pp. 185-205). Oakland, CA: New Harbinger.
- Unsworth, N., & McMillan, B. D. (2013). Mind wandering and reading comprehension: Examining the roles of working memory capacity, interest, motivation, and topic experience. *Journal of Experimental Psychology: Learning, Memory, and Cognition*, *39*(3), 832.
- Unsworth, N., McMillan, B. D., Brewer, G. A., & Spillers, G. J. (2012). Everyday attention failures: An individual differences investigation. *Journal of experimental psychology: learning, memory, and cognition*, *38*(6), 1765.
- Van Dam, N. T., Earleywine, M., & Borders, A. (2010). Measuring mindfulness? An item response theory analysis of the Mindful Attention Awareness Scale. *Personality and Individual Differences*, *49*(7), 805-810.
- Van Ijzendoorn, M. H., & Schuengel, C. (1996). The measurement of dissociation in normal and clinical populations: Meta-analytic validation of the Dissociative Experiences Scale (DES). *Clinical Psychology Review*, *16*(5), 365-382.
- Van Veen, V., & Carter, C. S. (2002). The anterior cingulate as a conflict monitor: fMRI and ERP studies. *Physiology & behavior*, *77*(4), 477-482.
- Wagenmakers, E. J. (2007). A practical solution to the pervasive problems of p values. *Psychonomic Bulletin & Review*, *14*(5), 779-804.
- Walach, H., Buchheld, N., Buttenmüller, V., Kleinknecht, N., & Schmidt, S. (2006). Measuring mindfulness—the Freiburg mindfulness inventory (FMI). *Personality and Individual Differences*, *40*(8), 1543-1555.

- Waller, N., Putnam, F. W., & Carlson, E. B. (1996). Types of dissociation and dissociative types: A taxometric analysis of dissociative experiences. *Psychological Methods, 1*(3), 300.
- Wenk-Sormaz, H. (2005). Meditation can reduce habitual responding. *Alternative therapies in health and medicine, 11*(2), 42.
- Williams, J. M. G. (2010). Mindfulness and psychological process. *Emotion, 10*(1), 1.
- Williams, J. M. G., & Kabat-Zinn, J. (2011). Mindfulness: diverse perspectives on its meaning, origins, and multiple applications at the intersection of science and dharma. *Contemporary Buddhism, 12*(01), 1-18.
- Winkielman, P., & Schooler, J. (2008). Unconscious, conscious, and metaconscious in social cognition. *Social cognition: The basis of human interaction, 49-69*.
- Wright, D. B., & Loftus, E. F. (1999). Measuring dissociation: Comparison of alternative forms of the dissociative experiences scale. *American Journal of Psychology, 112*(4), 497-519.
- Xu, M., Purdon, C., Seli, P., & Smilek, D. (2017). Mindfulness and mind wandering: The protective effects of brief meditation in anxious individuals. *Consciousness and Cognition, 51*, 157-165.
- Zeidan, F., Johnson, S. K., Diamond, B. J., David, Z., & Goolkasian, P. (2010). Mindfulness meditation improves cognition: evidence of brief mental training. *Consciousness and cognition, 19*(2), 597-605.
- Ziegler, D. A., Mishra, J., & Gazzaley, A. (2015). The Acute and Chronic Impact of Technology on our Brain. *The Wiley Blackwell Handbook of Psychology, Technology and Society, 544*.
- Zoogman, S., Goldberg, S. B., Hoyt, W. T., & Miller, L. (2015). Mindfulness interventions with youth: A meta-analysis. *Mindfulness, 6*(2), 290-302.

APPENDIX A. MIND WANDERING QUESTIONNAIRE

(MWQ, MRAZEK, PHILLIPS ET AL., 2013)

Using the 1-6 scale below, please indicate how often you currently have each experience.

1	2	3	4	5	6
Almost Never	Very Infrequently	Somewhat Infrequently	Somewhat Frequently	Very Frequently	Almost Always

1. I have difficulty maintaining focus on simple or repetitive work.
2. While reading, I find I haven't been thinking about the text and must therefore read again.
3. I do things without paying full attention.
4. I find myself listening with one ear, thinking about something else at the same time.
5. I mind-wander during lectures or presentations.

APPENDIX B. MEDIA MULTITASKING INDEX

(MMI, OPHIR ET AL., 2009)

Watching Television or videos

Do you watch TV or videos? This would include watching network/cable/on-demand/TiVo programs, as well as watching videos and/or DVDs on a TV or on a computer.

Yes/No

When you are watching television or videos, how often are you also doing the following at the same time:

1	2	3	4
Never	A little of the time	Some of the time	Most of the time

- Doing homework or reading for class
- Playing video games
- Surfing the web or doing other online activities
- Listening to music
- Using social media
- Texting/SMS

Participants answered the same set of questions for watching TV or videos, surfing the Web, using social media, playing video games, reading, doing homework, listening to lectures or presentations. The following media uses that are part of the original MMI were not included in the modified version of the MMI used in the current dissertation: listening to music, listening to non-musical audio, talking on the phone, and reading/writing emails.

APPENDIX C. MINDFUL ATTENTION AWARENESS SCALE

(MAAS, BROWN & RYAN, 2003)

1	2	3	4	5	6
Almost Never	Very Infrequently	Somewhat Infrequently	Somewhat Frequently	Very Frequently	Almost Always

1. I could be experiencing some emotion and not be conscious of it until some time later.
2. I break or spill things because of carelessness, not paying attention, or thinking of something else.
3. I find it difficult to stay focused on what's happening in the present.
4. I tend to walk quickly to get where I'm going without paying attention to what I experience along the way.
5. I tend not to notice feelings of physical tension or discomfort until they really grab my attention.
6. I forget a person's name almost as soon as I've been told it for the first time.
7. It seems I am "running on automatic," without much awareness of what I'm doing.
8. I rush through activities without being really attentive to them.
9. I get so focused on the goal I want to achieve that I lose touch with what I'm doing right now to get there.
10. I do jobs or tasks automatically, without being aware of what I'm doing.
11. I find myself listening to someone with one ear, doing something else at the same time.
12. I drive places on 'automatic pilot' and then wonder why I went there.
13. I find myself preoccupied with the future or the past.
14. I find myself doing things without paying attention.
15. I snack without being aware that I'm eating.

APPENDIX D. DISSOCIATIVE EXPERIENCES SCALE

(DES, BERNSTEIN & PUTNAM, 1986)

This questionnaire consists of 20 questions* about experiences you may have had in your daily life. We are interested in how often you have had these experiences. To answer the questions, please determine to what degree the experience described in the question applies to you and circle the appropriate number to show what percentage of the time you have had the experience.

Never | 0% 10 20 30 40 50 60 70 80 90 100% | Always

1. Some people have the experience of driving a car and suddenly realizing that they don't remember what has happened during all or part of the trip.
2. Some people find that sometimes they are listening to someone talk and they suddenly realize that they did not hear part or all of what was just said.
3. Some people have the experience of finding themselves dressed in clothes that they don't remember putting on.
4. Some people sometimes find that they are approached by people that they do not know who call them by another name or insist that they have met them before.
5. Some people find that they have no memory for some important events in their lives (for example, a wedding or graduation).
6. Some people have the experience of being accused of lying when they do not think that they have lied.
7. Some people have the experience of looking in a mirror and not recognizing themselves.
8. Some people have the experience of sometimes remembering a past event so vividly that they feel as if they were reliving that event.

9. Some people have the experience of not being sure whether things that they remember happening really did happen or whether they just dreamed them.
10. Some people have the experience of being in a familiar place but finding it strange and unfamiliar.
11. Some people find that when they are watching television or a movie they become so absorbed in the story that they are unaware of other events happening around them.
12. Some people sometimes find that they become so involved in a fantasy or daydream that it feels as though it were really happening to them.
13. Some people find that they sometimes are able to ignore pain.
14. Some people find that they sometimes sit staring off into space, thinking of nothing, and are not aware of the passage of time.
15. Some people sometimes find that when they are alone they talk out loud to themselves.
16. Some people sometimes find that in certain situations they are able to do things with amazing ease and spontaneity that would usually be difficult for them (for example, sports, work, social interactions, etc.).
17. Some people sometimes find that they cannot remember whether they have done something or have just thought about doing that thing (for example, not knowing whether they have just mailed a letter or have just thought about mailing it).
18. Some people sometimes find evidence that they have done things that they do not remember doing.
19. Some people sometimes find writings, drawings, or notes among their belongings that they must have done but cannot remember doing.

20. Some people sometimes feel as if they are looking at the world through a fog so that people and objects appear far away or unclear.

*. The original DES is a 28-item questionnaire, but this dissertation used a 20-item modified version of the DES due to the sensitive nature of the remaining eight items concerned with traumatic experiences

APPENDIX E. TORONTO MINDFULNESS SCALE
(TMS, LAU ET AL., 2006)

We are interested in what you just experienced while listening to the audio recording. Below is a list of things that people sometimes experience. Please indicate the extent to which you agree with each statement. In other words, how well does the statement describe what you just experienced, just now?

0	1	2	3	4
Not at all	A little	Moderately	Quite a bit	Very much

1. I experienced myself as separate from my changing thoughts and feelings.
2. I was more concerned with being open to my experiences than controlling or changing them
3. I was curious about what I might learn about myself by taking notice of how I react to certain thoughts, feelings or sensations.
4. I experienced my thoughts more as events in my mind than as a necessarily accurate reflection of the way things 'really' are.
5. I was curious to see what my mind was up to from moment to moment.
6. I was curious about each of the thoughts and feelings that I was having.
7. I was receptive to observing unpleasant thoughts and feelings without interfering with them.
8. I was more invested in just watching my experiences as they arose, than in figuring out what they could mean.
9. I approached each experience by trying to accept it, no matter whether it was pleasant or unpleasant.

10. I remained curious about the nature of each experience as it arose.

11. I was aware of my thoughts and feelings without overidentifying with them.

12. I was curious about my reactions to things.

13. I was curious about what I might learn about myself by just taking notice of what my attention gets drawn to.

APPENDIX F. RETROSPECTIVE MEASURE OF MIND WANDERING

(DSSQ, MATTHEWS ET AL., 1999)

Please rate the extent to which you have engaged in the following thoughts while watching the lecture video.

1	2	3	4	5
Never	Once	A few times	Often	Very often

1. I thought about members of my family.
2. I thought about something that made me feel guilty.
3. I thought about personal worries.
4. I thought about something that made me feel angry.
5. I thought about something that happened earlier today.
6. I thought about something that happened in the recent past.
7. I thought about something that happened in the distant past.
8. I thought about something that might happen in the future.
9. I thought about how I should work more carefully.
10. I thought about how much time I had left.
11. I thought about how others have done on this task.
12. I thought about the difficulty of the problems.
13. I thought about my level of ability.
14. I thought about the purpose of the experiment.
15. I thought about how I would feel if I were told how I performed.
16. I thought about how often I get confused.

APPENDIX G. POST-VIDEO QUESTIONNAIRE

1. How interested were you in the topic of the lecture video?

Not at all Very much

2. How interested are you in this topic in general?

Not at all Very much

3. How motivated were you to learn the content of the lecture video?

Not at all Very much

4. How much did your overall motivation influence your performance on the test?

Not at all Very much

5. How much background knowledge do you have on the topic of the lecture video?

Not at all Very much

6. How much did your prior knowledge influence your performance on the test?

Not at all Very much

APPENDIX H. THE COMPREHENSION TEST USED IN EXPERIMENT 1

1. Which of the following is NOT one of the four tissue types discussed in the lecture?
 - a. **Blood***
 - b. Connective
 - c. Epithelium
 - d. Muscle

2. Which of the following is FALSE about homeostasis?
 - a. All organ systems integrate to maintain homeostasis of the body
 - b. Its primary function is to maintain conditions within the body that are compatible with the life of the cells
 - c. Problems in the maintenance of homeostasis can result in illnesses or pathophysiology
 - d. **The maintenance of homeostasis means that the body's response to its surrounding remains constant irrespective of environmental conditions.**

3. Which of the following is TRUE about the two fluid compartments, the intracellular fluid compartment (ICF) and extracellular fluid compartment (ECF)?
 - a. **ICF is larger than ECF**
 - b. ECF and ICF have similar contents
 - c. There is an equilibrium between ECF and ICF
 - d. There is no substance transfer between ECF and ICF

4. What is the correct order in which the components of reflex loops are involved in homeostasis control?
 - a. Stimulus, Integration Center, Effectors, Sensor
 - b. Sensor, Integration Center, Effectors, Stimulus
 - c. **Stimulus, Sensor, Integration Center, Effectors**
 - d. Sensor, Effectors, Integration Center, Stimulus

5. Which of the following is FALSE about the skin?
 - a. Its main function is protective
 - b. **It is the smallest organ of the human body**
 - c. It is an important barrier for the loss of water
 - d. It keeps some of the internal organs organized

6. Which of the following is FALSE about the steady state?
 - a. It is present between the intracellular fluid compartment (ICF) an extracellular fluid compartment (ECF)
 - b. There is a constant amount of substance within these two compartments in the steady state
 - c. **No energy expenditure is required to maintain the steady state between the two compartments**
 - d. In the steady state, the concentrations within these two compartments can be dissimilar

7. Which of the following is FALSE about what happens when you eat a bag of salty potato chips and drink a lot of water?
- The amount of sodium in your body increases
 - The volume of fluid compartments increases
 - The sodium concentration in your body increases
 - The sodium concentration in your body does not change**
8. Which of the following is TRUE about the relationship between total body water (TBW), intracellular fluid compartment (ICF) and extracellular fluid compartment (ECF)?
- TBW is approximately 90% of total body weight
 - ICF is 2/3 of TBW and ECF is 1/3 of TBW**
 - ICF is 1/3 of TBW and ECF is 2/3 of TBW
 - ECF and ICF have the same capacity; each is 1/2 of TBW
9. Intracellular fluid compartment (ICF) is bounded by _____.
- Cytoplasm
 - Plasma membrane**
 - IVF proteins
 - ATPase
10. Within intracellular fluid compartment (ICF), there is ____ concentrations of potassium (K) and ____ concentrations of sodium (Na). Within extracellular fluid compartment (ECF), there is ____ concentrations of potassium (K) and ____ concentrations of sodium (Na).
- High, small, high, small
 - Small, high, small, high
 - High, small, small, high**
 - Small, high, high small
11. Intravascular compartment (IVF) and interstitial fluid space (IS) are divided by a barrier consisting of _____.
- Connective tissue cells
 - Muscle tissue cells
 - Nervous tissue cells
 - Epithelial tissue cells**

12. Which of the fluid components stores the cytoplasm, liquid components within cells?
- Intracellular fluid compartment (ICF)**
 - Extracellular fluid compartment (ECF)
 - Intravascular fluid compartment (IVF)
 - Interstitial fluid space (IS)
13. How many of the organ systems in the human body will be considered in this class?
- 7
 - 8
 - 9**
 - 10
14. What will be the topic of the next lecture?
- The relationship between homeostasis and pathological conditions
 - Effects of homeostasis on wellness
 - Mechanisms involved in the maintenance of homeostasis**
 - General concepts in homeostasis

* Note that correct answers are typed in bold.

APPENDIX I. THOUGHT SAMPLING INSTRUCTIONS

Instructions for self-caught mind wandering reports

While you are watching the video, you may find that you begin to think about something that is unrelated to what you are watching. In other words, you may realize that you have zoned out. When this happens, please press the “Space” key on the keyboard. This lets us know how often and when you zone out during the lecture video. Do you have any questions about this?

Instructions for probe-caught mind wandering reports

In addition, at various during the lecture video, you will be interrupted with the following question:

What were you just thinking about?

1. The video.
2. How well I’m understanding the video.
3. A memory from the past.
4. Something in the future.
5. Current state of being (for example, I’m feeling hungry).
6. Thinking about or using another technology (for example, texting; checking Facebook).
7. Other.

APPENDIX J. CORRELATIONS AMONG STUDY VARIABLES IN EXPERIMENT 1

Table J1. Correlations among all study variables in Experiment 1

	MMI	DES	MWQ	MAAS	TMS	SC TUT	PC TUT	Retro TUT	Comp	WMC	INT	MOT	BG
MMI	.916												
DES	.217**	.952											
MWQ	.361**	.263**	.822										
MAAS	-.359**	-.424**	-.727**	.874									
TMS	.075	.223**	.101	-.174*	.867								
SC TUT	-.020	.040	.274**	-.156*	-.007	.894							
PC TUT	.067	.112	.271**	-.104	.029	.426**	.555						
Retro TUT	.223**	.259**	.315**	-.293**	.125	.395**	.475**	.867					
Comp	.015	-.060	-.010	-.081	.051	-.106	-.341**	-.227**	-				
WMC	-.100	.015	.025	-.059	.087	-.229**	-.033	.025	.037	-			
Interest	.030	-.036	-.102	.031	.079	-.217**	-.466**	-.310**	.439**	.096	.909		
Motivation	-.002	.038	-.054	-.031	.248**	-.046	-.277**	-.010	.263**	.083	.338**	-.060	
Background	.143	.112	.179*	-.159*	.112	.064	-.023	-.056	.286**	.070	.271**	.187*	.665

Values on the diagonal reflect Cronbach's alpha for each measure as a reliability estimate. WMC indicates the average OSPAN total score. MWQ, as a measure of mind wandering tendency, indicates the average score on the MWQ. MAAS, as a measure of trait mindfulness, indicates the average score on the MAAS. DES, as a measure of the frequency of dissociative experiences, indicates the average score on the DES. MMI, as a measure of media multitasking frequency, indicates the average score on the modified version of MMI. PC TUT, or probe-caught TUT, refers to the average proportion of probes to which participants indicated mind wandering. SC TUT, or self-caught TUT, refers to the average frequency of self-caught mind wandering. Retro TUT, or retrospective TUT, refers to the average score on the retrospective measure of mind wandering. Comp, or comprehension, refers to the average proportion of correct answers in the comprehension test. TMS, as a measure of state mindfulness, refers to the average score on the TMS. Interest refers to self-reported interest in the lecture video content, motivation refers to self-reported motivation to learn from the lecture video and background refers to self-reported prior knowledge of the lecture material. *. $p < .05$, **. $p < .01$

APPENDIX K. ADDITIONAL ANALYSIS FOR WORKING MEMORY CAPACITY

While a regression-based approach to individual differences analysis was adopted in the current dissertation, the role of working memory capacity (WMC), as measured by OSPAN, in the propensity for mind wandering was further analyzed, by dichotomizing the OSPAN score. As is commonly done in WMC research, participants were divided into low and high WMC groups based on their OSPAN scores. Specifically, participants with an OSPAN score one standard deviation below the mean were categorized into the “Low WMC” group ($n = 29$, 16.4% of the sample), and participants with an OSPAN score one standard deviation above the mean were categorized into the “High WMC” group ($n = 23$, 13.0% of the sample).

An independent samples t test was conducted to compare these two groups in the propensity for mind wandering during the lecture video, as indexed by the proportion of probe-caught mind wandering episodes. Results revealed no significant differences between low WMC individuals ($M = .62$, $SD = .30$) and high WMC individuals ($M = .60$, $SD = .28$) in the propensity for mind wandering during the lecture video, $t(50) = .26$, $p = .80$. There were also no significant differences between low WMC individuals ($M = .56$, $SD = .20$) and high WMC individuals ($M = .59$, $SD = .17$) in their performance on the lecture comprehension test, $t(50) = .54$, $p = .59$.

A bootstrapped mediation analysis was conducted using the PROCESS macro for SPSS (Hayes, 2013) to assess the fit of the same mediation model presented earlier in Figure 4. The results of the mediation analysis are presented in Figure K1. As can be seen from Figure K1, the dichotomized working memory capacity variable did not predict mind wandering, $F(1, 50) = .066$, $MSE = .084$, $p = .799$, $R^2 = .00$, nor did it have any direct

or indirect effects on lecture comprehension, $F(1, 50) = .292$, $MSE = .036$, $p = .592$, $R^2 = .01$. Mind wandering, however, did predict performance decrements on the comprehension test, $b = -.23$, $p = .012$, 95% CI $[-.403, -.051]$, $F(2, 49) = 3.54$, $MSE = .032$, $p = .037$, $R^2 = .13$, which is consistent with the findings of the mediation model presented in Figure 4.

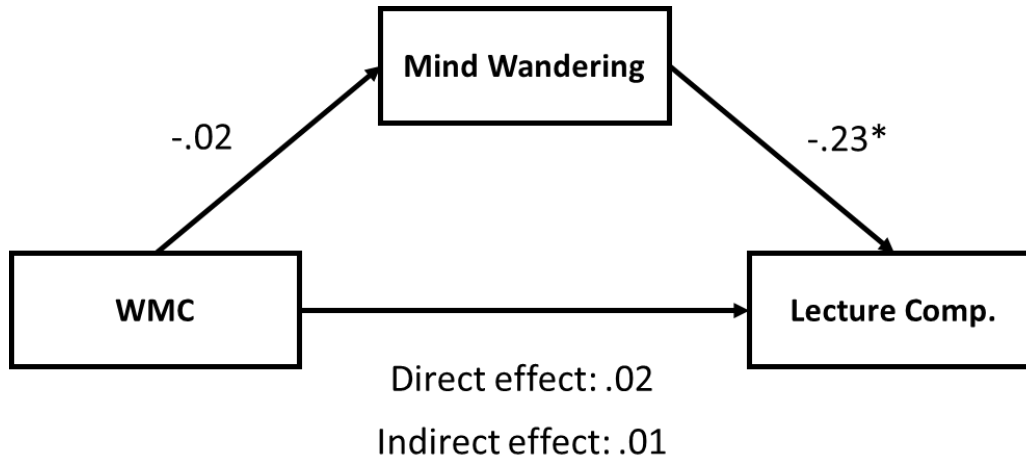

Figure 11. Regression coefficients for the relationship between working memory capacity (WMC) and lecture comprehension as mediated by mind wandering. Working memory capacity is dichotomized as low WMC and high WMC. Mind wandering indicates the proportion of probe-caught TUTs. Lecture comprehension indicates the proportion of correct answers on the comprehension test.

APPENDIX L. DESCRIPTIVE STATISTICS FOR SART PERFORMANCE MARKERS

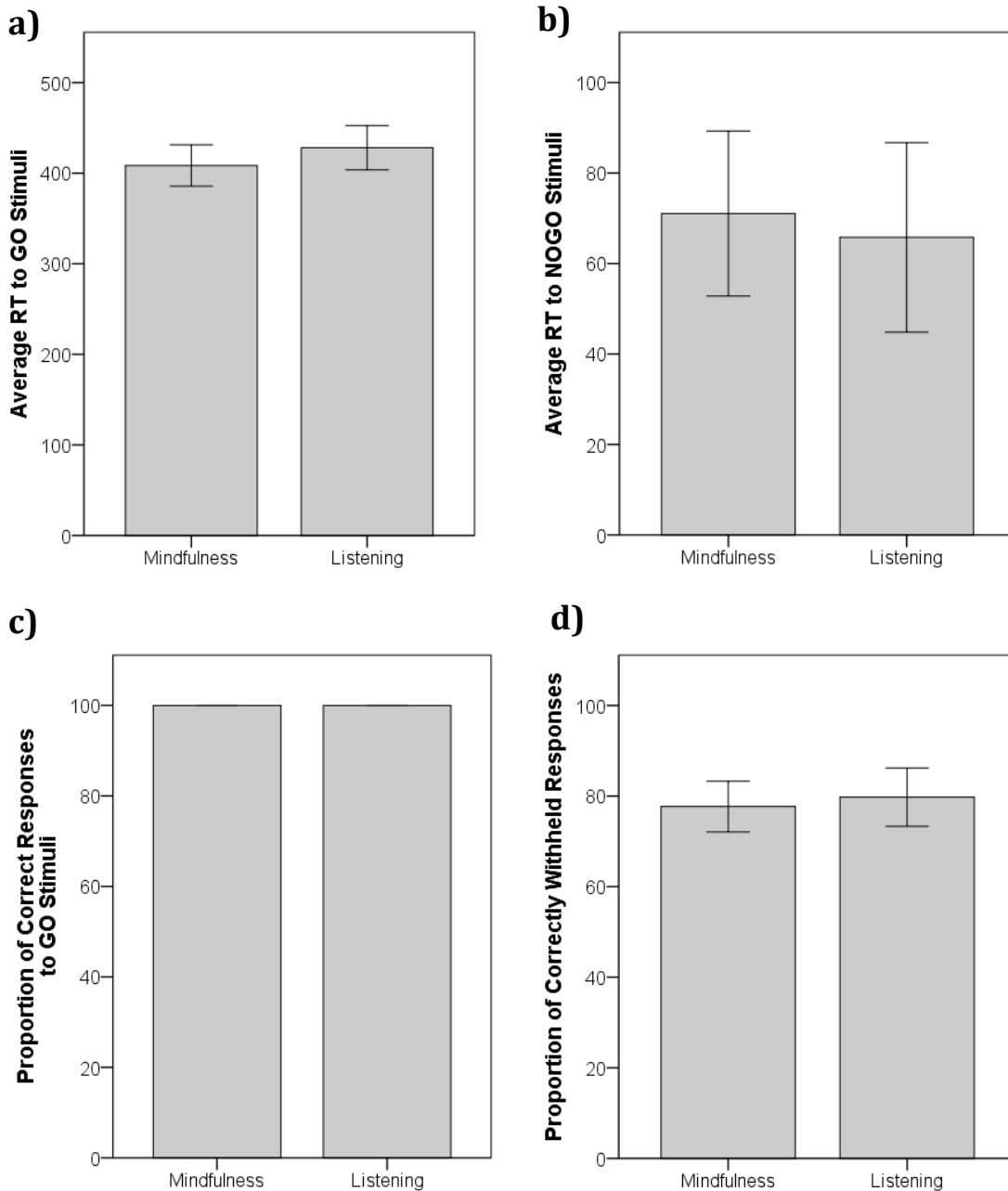

Figure 12. Bar graphs representing the means for (a) reaction time to GO stimuli, (b) reaction time to NOGO stimuli, (c) proportion of correct responses to GO stimuli, and (d) proportion of correctly withheld responses to NOGO stimuli. As seen in (b) average RT to NOGO stimuli, which would have been zero if there were no SART errors, is extremely low. RTs under 100ms are considered anticipations that reflect absent-minded responding without processing the immediate task-relevant stimuli (Cheyne et al., 2009). As seen in (c) participants correctly responded to almost all of the GO stimuli with a 99.97% ($SD = .082$) accuracy rate for the mindfulness group and a 99.98% ($SD = .061$) accuracy rate for the listening group.

APPENDIX M. INSTITUTIONAL REVIEW BOARD APPROVAL

IOWA STATE UNIVERSITY
OF SCIENCE AND TECHNOLOGY

Institutional Review Board
Office for Responsible Research
Vice President for Research
1138 Pearson Hall
Ames, Iowa 50011-2207
515 294-4500
FAX 515 294-4207

Date: 3/11/2016

To: Caglar Yildirim
N 057 Lagomarcino Hall
Ames, IA 50011

CC: Dr. Veronica Dark
W112 Lagomarcino Hall

From: Office for Responsible Research

Title: Investigating the Effect of Mindfulness on Mind Wandering

IRB ID: 15-706

Approval Date: 3/10/2016 **Date for Continuing Review:** 12/22/2017

Submission Type: Modification **Review Type:** Expedited

The project referenced above has received approval from the Institutional Review Board (IRB) at Iowa State University according to the dates shown above. Please refer to the IRB ID number shown above in all correspondence regarding this study.

To ensure compliance with federal regulations (45 CFR 46 & 21 CFR 56), please be sure to:

- **Use only the approved study materials** in your research, including the recruitment materials and informed consent documents that have the IRB approval stamp.
- **Retain signed informed consent documents for 3 years after the close of the study**, when documented consent is required.
- **Obtain IRB approval prior to implementing any changes** to the study by submitting a Modification Form for Non-Exempt Research or Amendment for Personnel Changes form, as necessary.
- **Immediately inform the IRB of (1) all serious and/or unexpected adverse experiences** involving risks to subjects or others; and (2) **any other unanticipated problems involving risks** to subjects or others.
- **Stop all research activity if IRB approval lapses**, unless continuation is necessary to prevent harm to research participants. Research activity can resume once IRB approval is reestablished.
- **Complete a new continuing review form** at least three to four weeks prior to the **date for continuing review** as noted above to provide sufficient time for the IRB to review and approve continuation of the study. We will send a courtesy reminder as this date approaches.

Please be aware that IRB approval means that you have met the requirements of federal regulations and ISU policies governing human subjects research. **Approval from other entities may also be needed.** For example, access to data from private records (e.g. student, medical, or employment records, etc.) that are protected by FERPA, HIPAA, or other confidentiality policies requires permission from the holders of those records. Similarly, for research conducted in institutions other than ISU (e.g., schools, other colleges or universities, medical facilities, companies, etc.), investigators must obtain permission from the institution(s) as required by their policies. **IRB approval in no way implies or guarantees that permission from these other entities will be granted.**

Upon completion of the project, please submit a Project Closure Form to the Office for Responsible Research, 1138 Pearson Hall, to officially close the project.

Please don't hesitate to contact us if you have questions or concerns at 515-294-4566 or IRB@iastate.edu.